

PRO-LINE PRO-2

1:10 2WD SHORT COURSE BUGGY KIT



POWERSTROKE
PERFORMANCE SHOCKS

PROTRAC
SUSPENSION

PRO-2

1:10 2WD SHORT COURSE BUGGY KIT

Thank you for purchasing Pro-Line's PRO-2 Buggy!
For over 30 years, Pro-Line has designed and manufactured the best RC accessories in the world. Pro-Line has taken the best performance parts and

combined them into one complete kit. Congratulations on making the right decision and joining Team Pro-Line in making history!

INCLUDED PERFORMANCE PARTS

- Pro-Line Performance Transmission
- PRO-2 LCG Performance Chassis
- PowerStroke Shocks
- ProTrac Suspension Kit
- Performance Steering Kit
- PRO-2 SC Buggy Body
- Secure-Loc Body Mount System
- Blockade M3 Pre-Mounted Tires
- Short Course Closed Cell Inserts
- F-11 ProTrac Offset Black Wheels
- Military-grade components

Enjoy your Ride!
From your friends at Pro-Line

This assembly manual contains instructions for building your new PRO-2 Buggy. Please take your time building the kit according to the instructions and become familiar with the steps.

Pro-Line is continually improving our products; consequently, actual parts included in the PRO-2 Buggy kit may appear slightly different than the images that appear in the manual.

TOOLS REQUIRED



1.5mm HEX



2.0mm HEX



2.5mm HEX



5mm NUT DRIVER



5.5mm NUT DRIVER

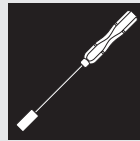

7mm NUT DRIVER

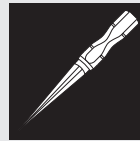

BODY REAMER



SIDE-CUT PLIERS



BODY SCISSORS

EQUIPMENT REQUIRED



RADIO

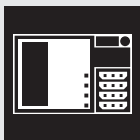

RECEIVER

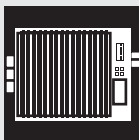

ESC

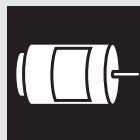

MOTOR

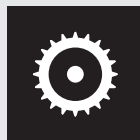

PINION GEAR



SERVO & HORN

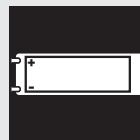

BATTERY

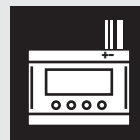

CHARGER

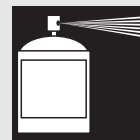

PAINT



SCAN FOR HELP

HELP AND INFORMATION

Installation manuals and videos can be found on our website at prolineracing.com/pro-2/build
For any help you may need, you can call our tech support line at 1-800-899-RACE(7223).



SCAN TO REGISTER

REGISTRATION

Register your kit online at prolineracing.com/pro-2/register
or call 1-800-899-RACE(7223).

WARNING!

This is NOT a toy and is NOT suitable for children under 14 years old. This kit contains many small parts which are potential choking hazards. Keep all components out of reach of small children.

HEALTH WARNING!

This product contains chemicals known to the State of California to cause cancer, birth defects, or other reproductive harm. This kit is a high performance radio controlled model kit and can cause harm or personal injury. All liquids contained in this kit are not to be swallowed. Never touch rotating parts as this can cause injury.

HARDWARE USED
(ACTUAL SIZE)

1

 x 2
M2.5 x 6 SHCS

 x 2
M3 x 8 SHCS

BUMPER BAG

Front Bumper Assembly

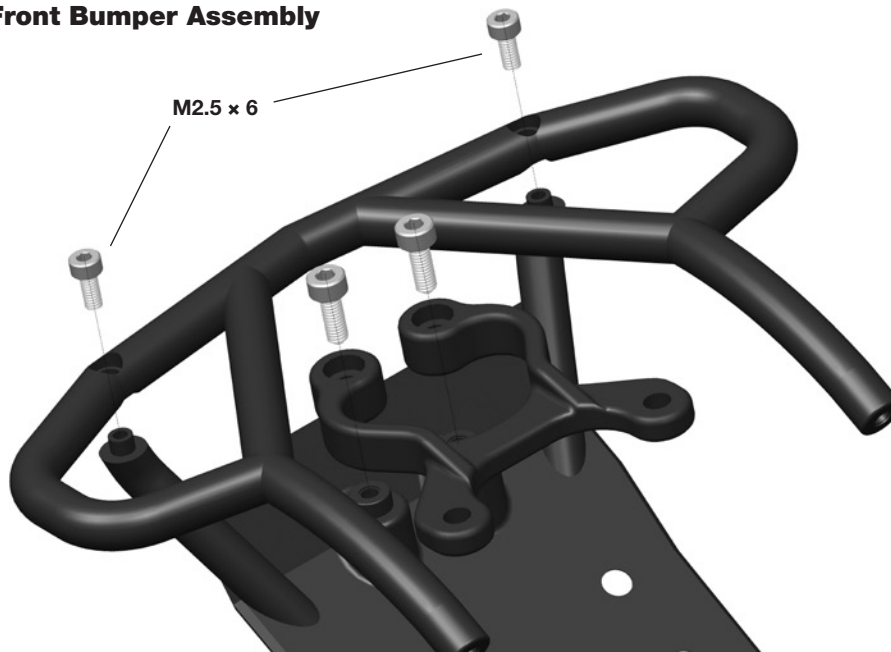

HARDWARE USED
(ACTUAL SIZE)

2

 x 2
M3 x 14 BHCS
(BAG B)

CAGE BAG, BAG A & B

Front Shock Tower to Bulkhead

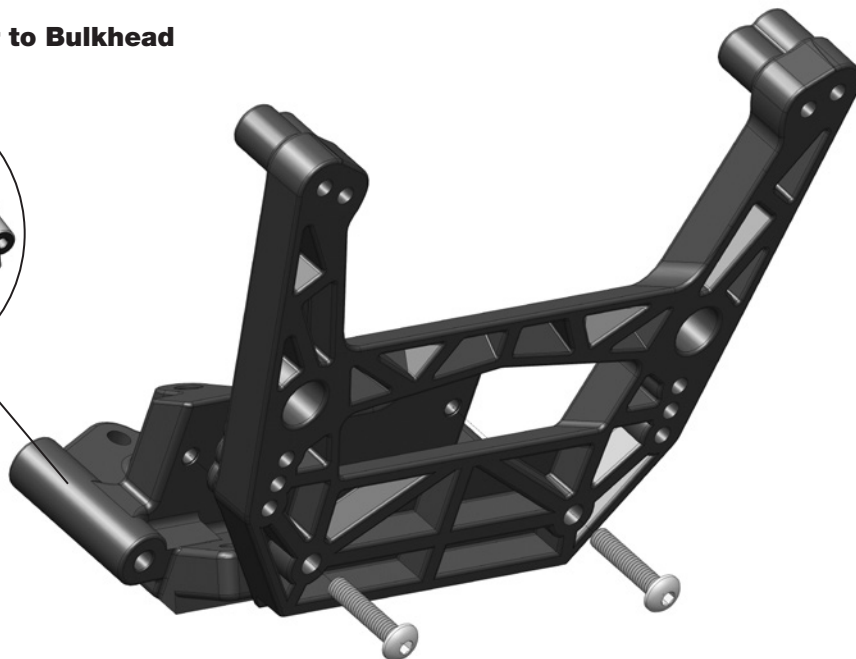
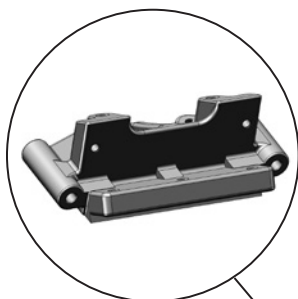

HARDWARE USED
(ACTUAL SIZE)

3

 x 4
M4 x 12 FHCS

BAG A

Front Bumper to Bulkhead

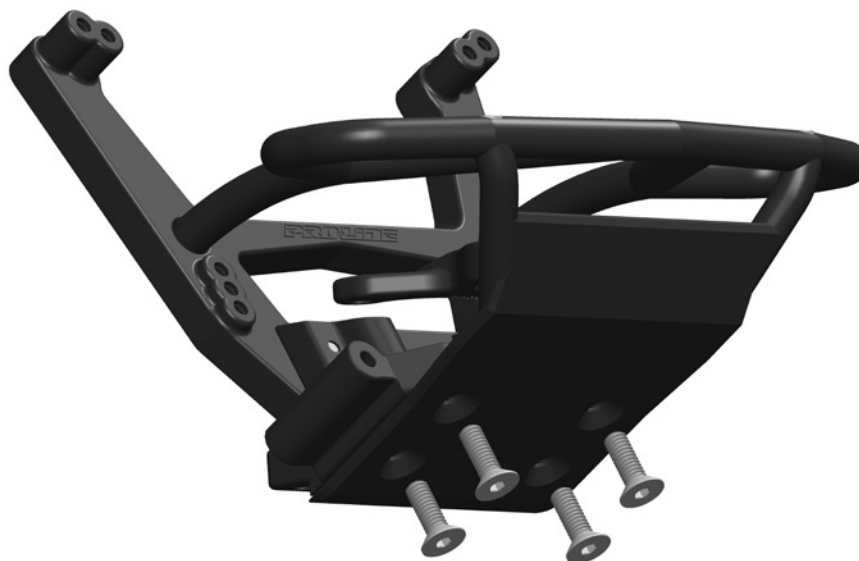

HARDWARE USED
(ACTUAL SIZE)

4

BAG C

Shock Mounting Hardware

OUTSIDE HOLE

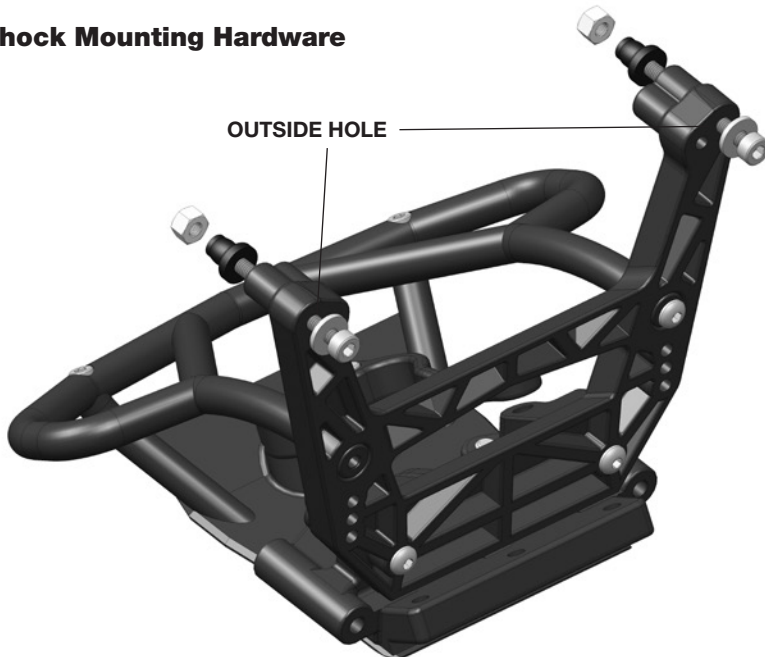

M3 X 30 SHCS



M3 Washer



Ball Ends



M3 Locknut

HARDWARE USED
(ACTUAL SIZE)

5

BUMPER BAG

Front Bumper to Shock Tower



M3 x 8 BHCS



M3 x 9 Washer

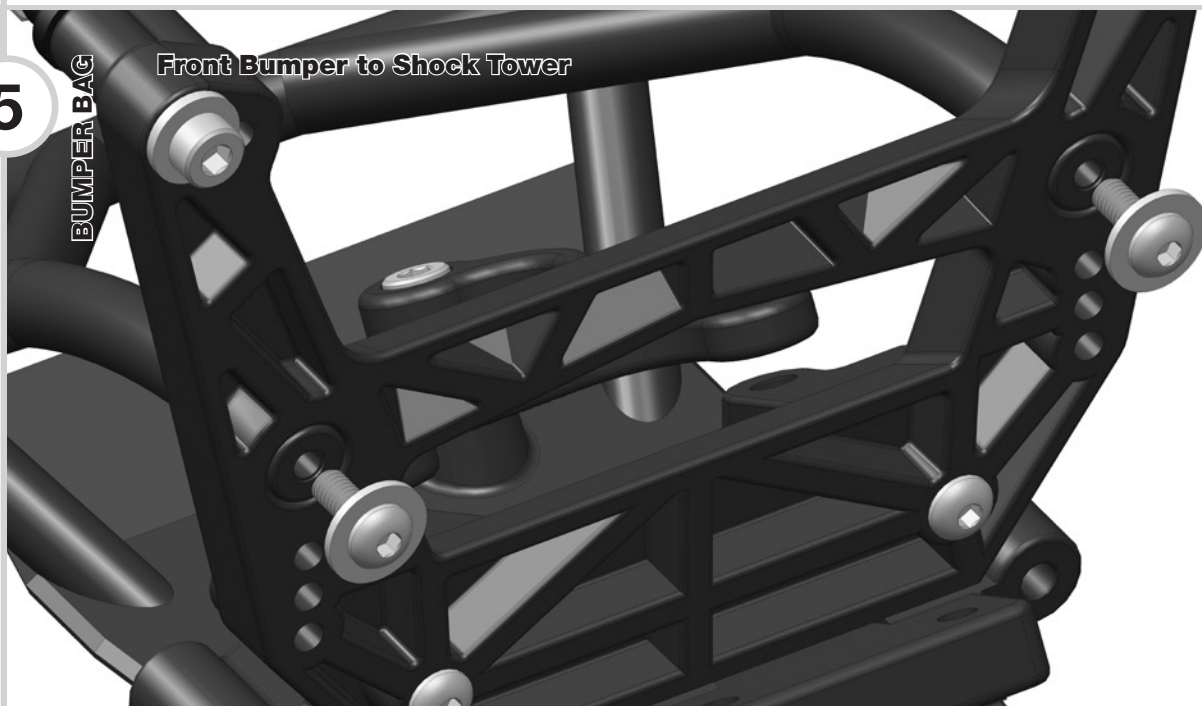

HARDWARE USED
(ACTUAL SIZE)

6

BAG E & PROTRAC BAG

Front Camber Link Rod Ends

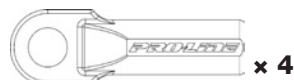

Long Rod Ends



USE INCLUDED TURNBUCKLE WRENCH

HARDWARE USED
(ACTUAL SIZE)

7

BAG E

Front Camber Link Pivot Balls

 x 2
Small Inner Pivot Balls

 x 2
Large Inner Pivot Balls

DRIVER'S SIDE LINK

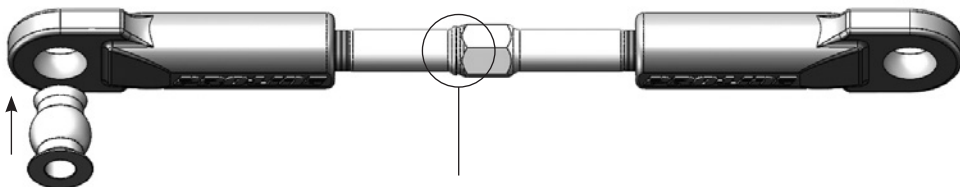

KEEP THESE MARKS ON DRIVER'S SIDE

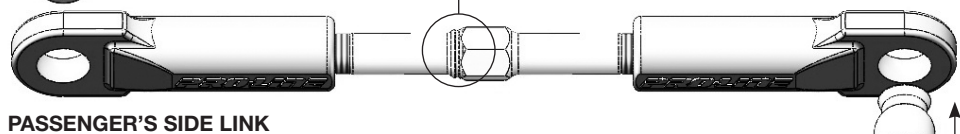

PASSENGER'S SIDE LINK

"DRIVER'S SIDE" AND "PASSENGER'S SIDE" REFER TO U.S. STANDARDS

HARDWARE USED
(ACTUAL SIZE)

8

BAG E

Front Camber Links to Shock Tower

 x 2
M3 x 12 Low Profile



KEEP THESE MARKS ON DRIVER'S SIDE

HARDWARE USED
(ACTUAL SIZE)

9

BAG B, F & PROTRAC BAG

Front Arms & Hinge Pin Brace to Bulkhead

 x 2
Front Inner Hinge Pin

 x 2
M3 Locknut

Hinge Pin Brace x 1
(Bag B)

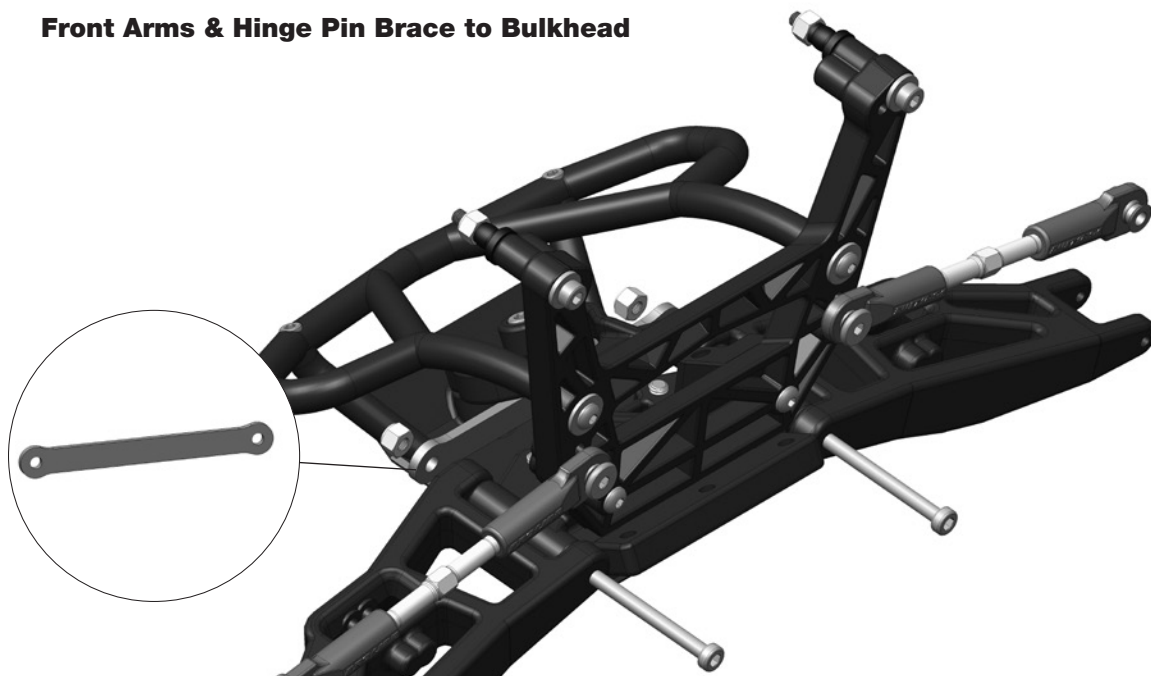

HARDWARE USED
(ACTUAL SIZE)

10

BAG G

Front Hub Assembly

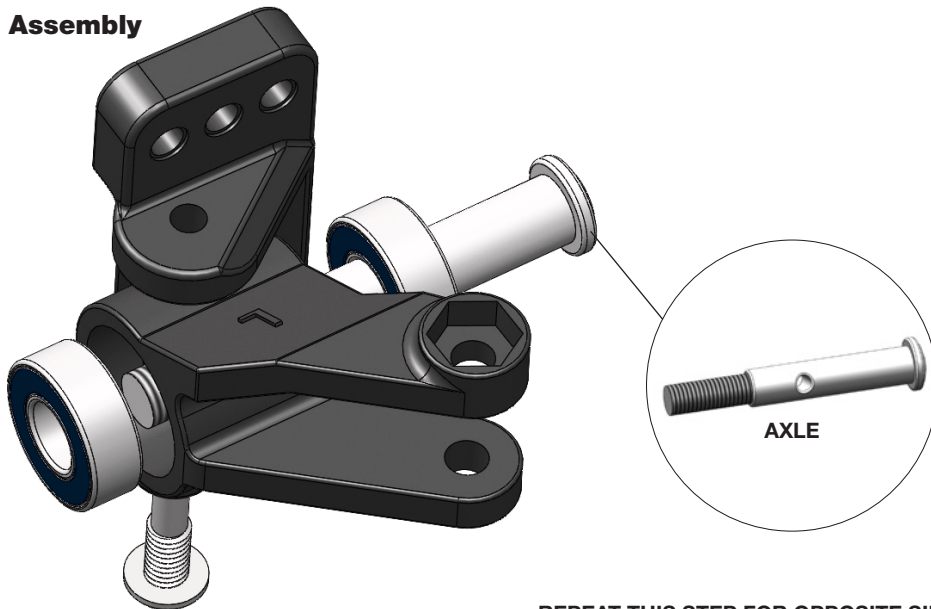

REPEAT THIS STEP FOR OPPOSITE SIDE

 x 4
5 x 11 Bearing

 x 2
King Pin

Axle x 2

HARDWARE USED
(ACTUAL SIZE)

11

BAG G & H

Front Wheel Hex Assembly

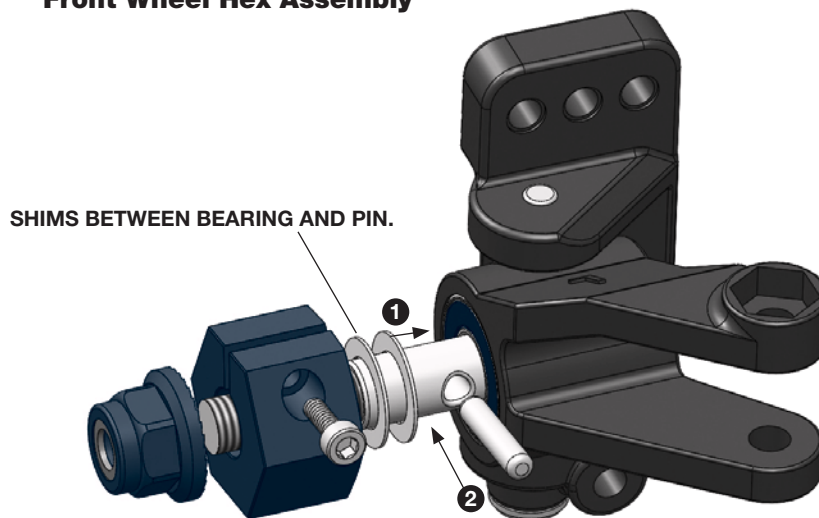

REPEAT THIS STEP FOR OPPOSITE SIDE

SHIMS BETWEEN BEARING AND PIN.

 x 2
Cross Pin
(Bag G)

 x 4
5 x 8 x 0.25 Shims
(Bag G)

 x 2
Serrated Locknut
(Bag G)

 x 2
M1.6 x 6 SHCS
(Bag H)

HARDWARE USED
(ACTUAL SIZE)

12

BAG F & G

Front Hub Assembly to Camber Link and Arm

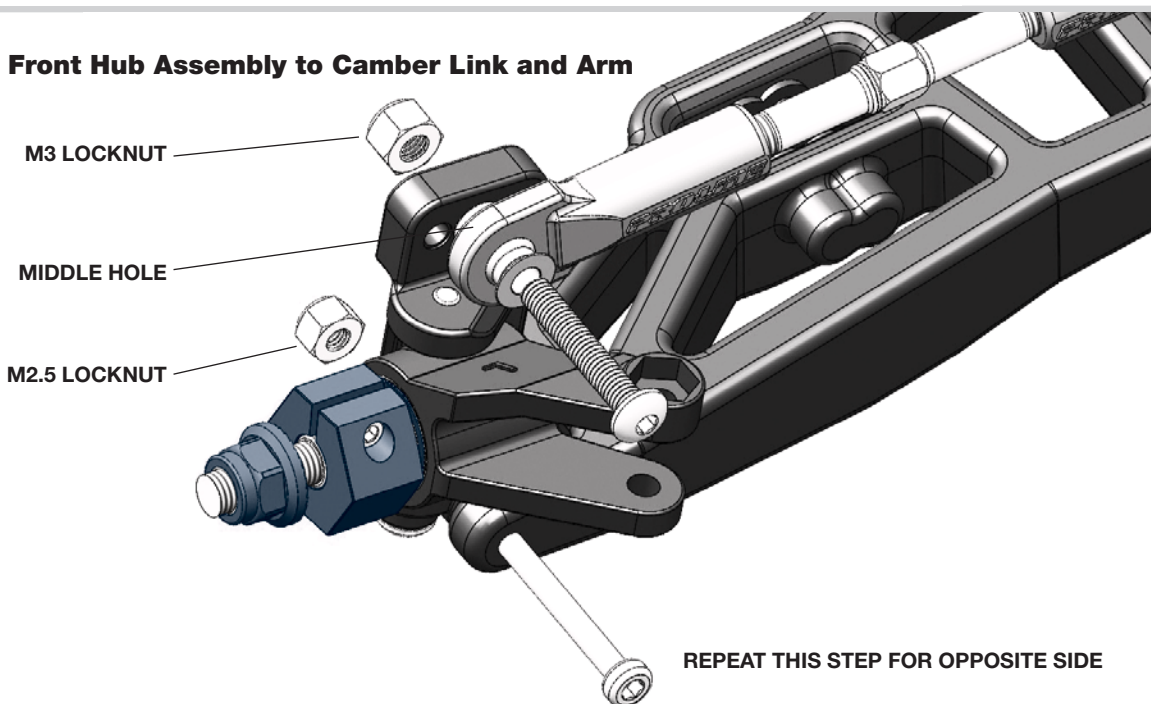

REPEAT THIS STEP FOR OPPOSITE SIDE

 x 2
Front Outer Hinge Pin
(Bag F)

 x 2
M2.5 Locknut
(Bag F)

 x 2
M3 x 18 BHCS
(Bag G)

 x 2
M3 Locknut

HARDWARE USED
(ACTUAL SIZE)

13



Short Rod Ends x 4



Large Pivot Balls x 4

BAG E & PROTRAC BAG

Steering Links to Rod Ends & Pivot Balls



70mm (ACTUAL SIZE)

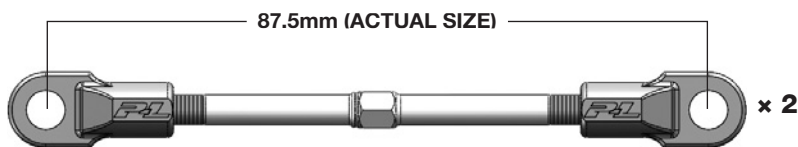

87.5mm (ACTUAL SIZE)



USE INCLUDED TURNBUCKLE WRENCH, REPEAT THIS STEP FOR OPPOSITE SIDE

HARDWARE USED
(ACTUAL SIZE)

14



M3 x 18 BHCS x 2



M3 Locknut x 2

BAG G

Steering Link to Steering Knuckle

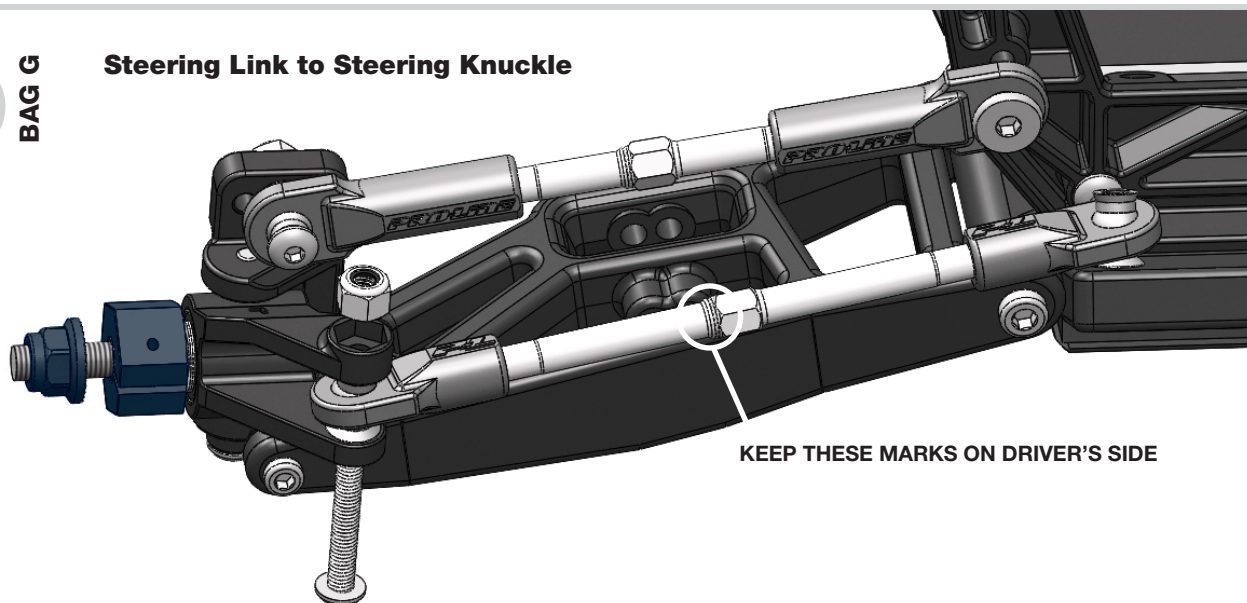

KEEP THESE MARKS ON DRIVER'S SIDE

REPEAT THIS STEP FOR OPPOSITE SIDE

HARDWARE USED
(ACTUAL SIZE)

15



M3 Locknut x 2

BAG B

Steering Links to Steering Kit

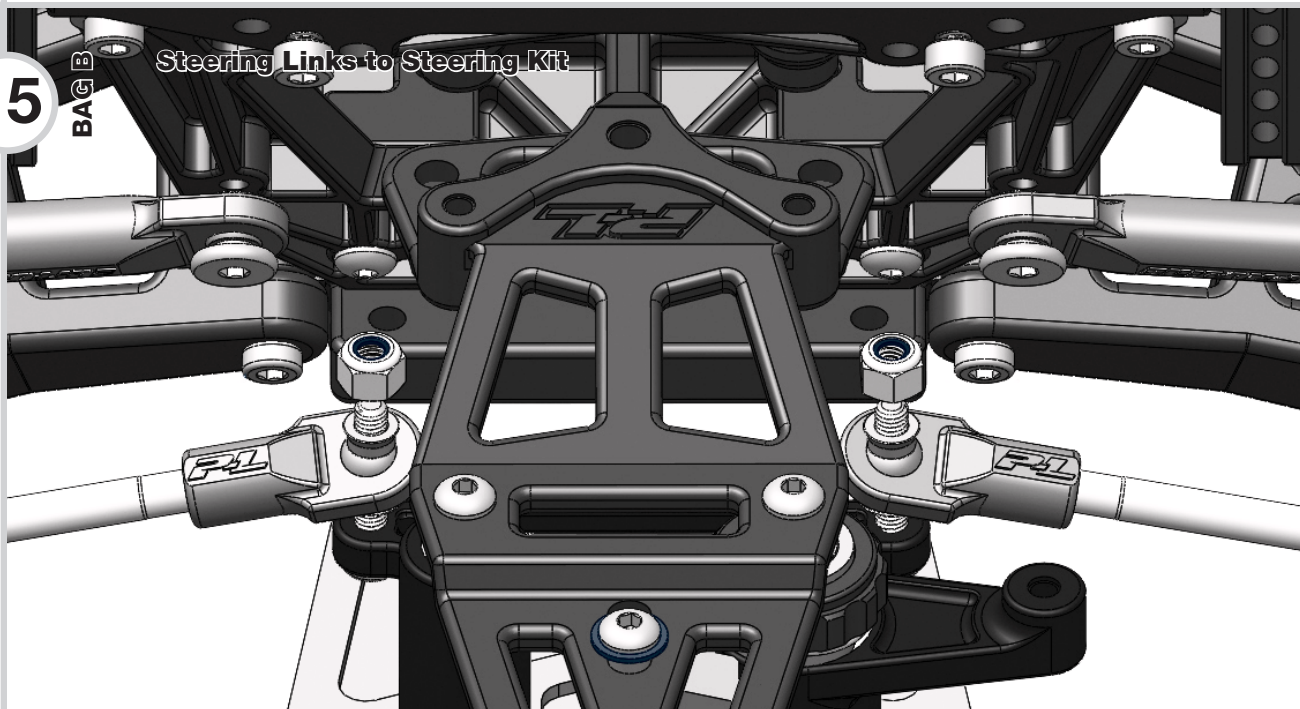

HARDWARE USED
(ACTUAL SIZE)

16

BAG B

Assemble Front End to Chassis

 **x 3**
M4 x 10 FHCS

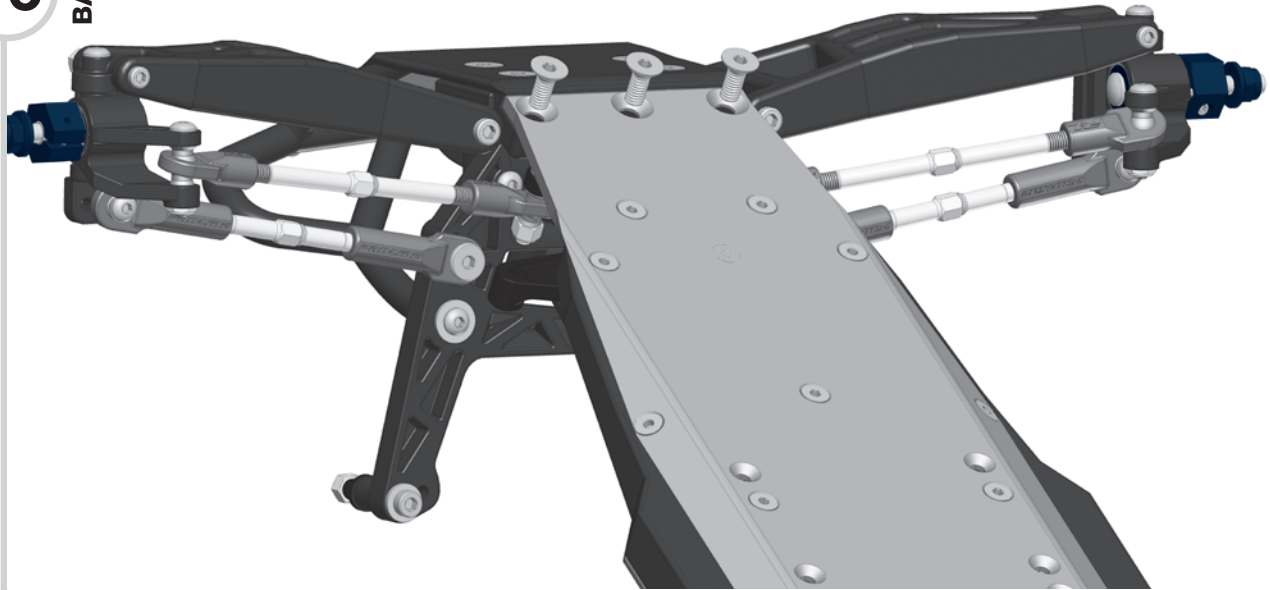

HARDWARE USED
(ACTUAL SIZE)

17

BAG A

Front Bumper Brace to Front Bulkhead

 **x 2**
M4 x 14 BHCS

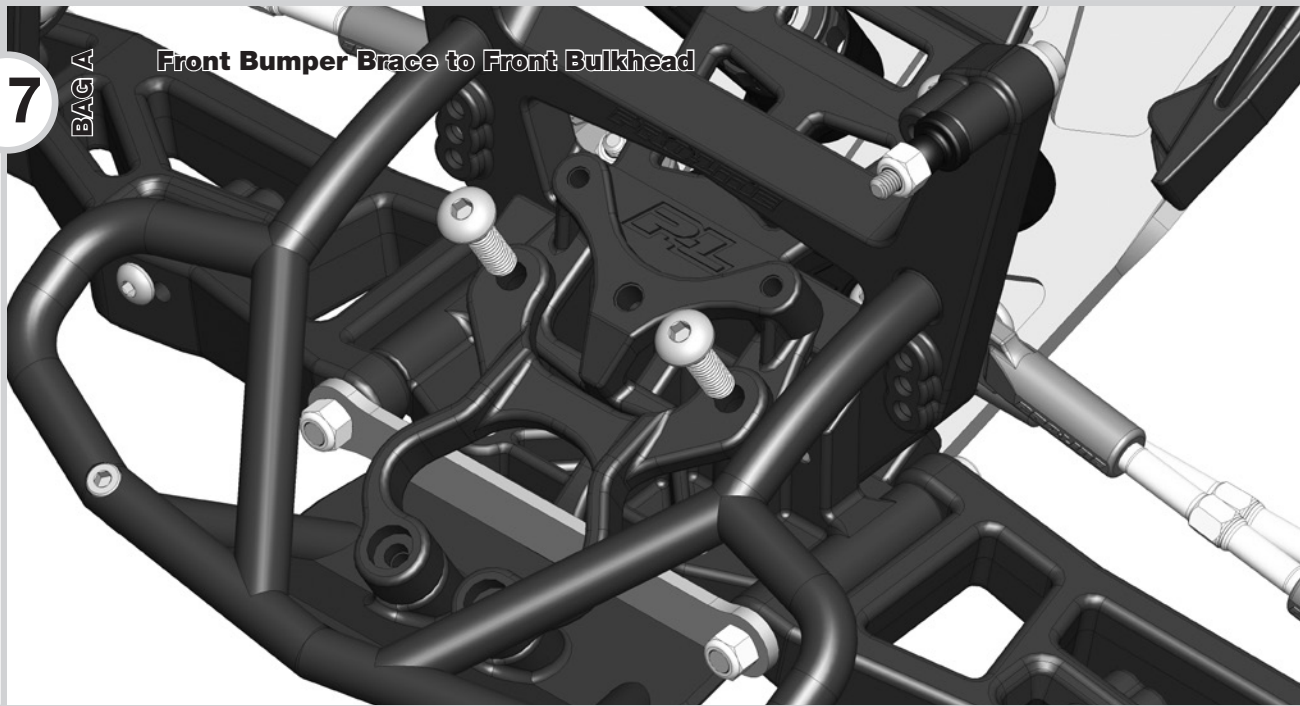

HARDWARE USED
(ACTUAL SIZE)

18

BAG C & PROTRAC BAG

Rear Shock Mounting Hardware

 **x 2**
M3 x 25 SHCS

 **x 2**
M3 Washer

 **x 2**
Ball Ends

 **x 2**
M3 Locknut

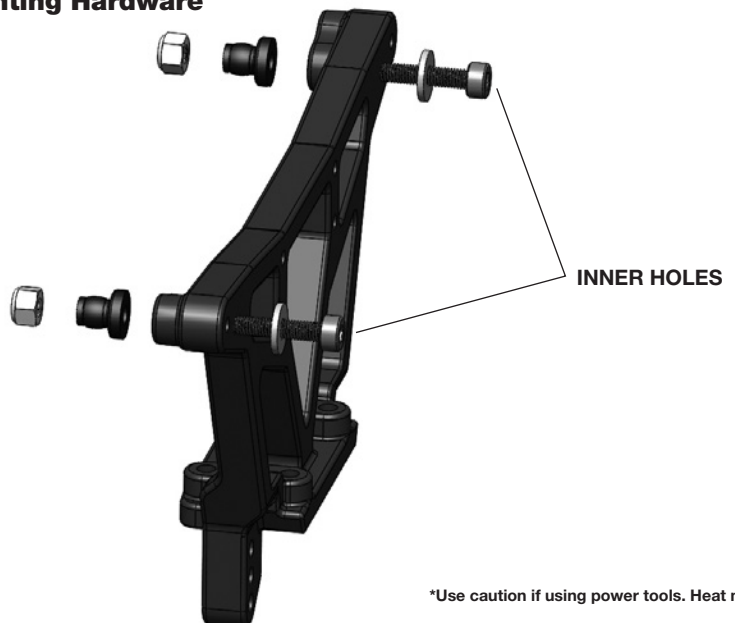

*Use caution if using power tools. Heat may melt plastic.

HARDWARE USED
(ACTUAL SIZE)

19

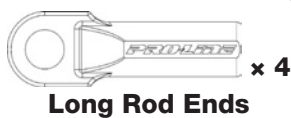

BAG E & PROTRAC BAG

Rear Camber Links to End Ends & Pivot Balls



KEEP THESE MARKS ON DRIVER'S SIDE



USE INCLUDED TURNBUCKLE WRENCH

HARDWARE USED
(ACTUAL SIZE)

20



BAG E

Rear Camber Links to Shock Tower

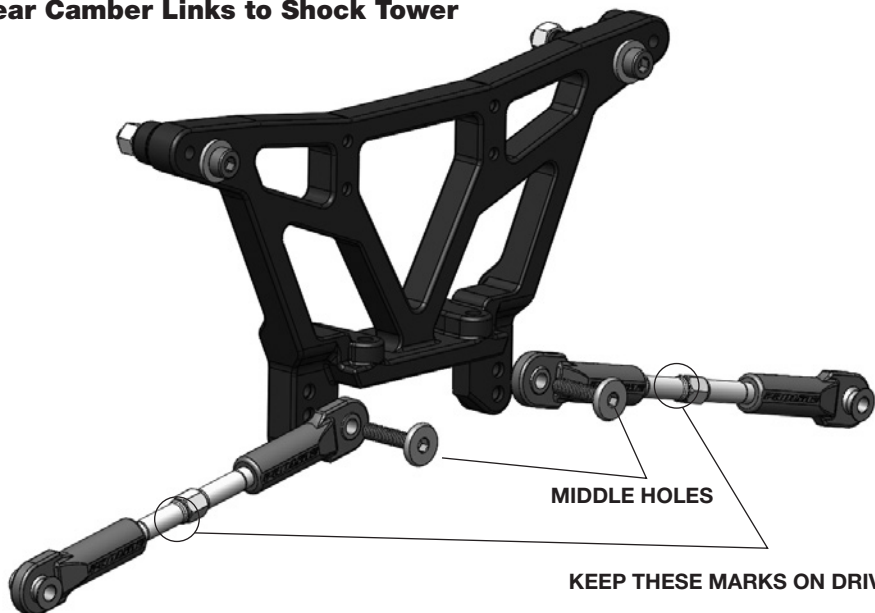

HARDWARE USED
(ACTUAL SIZE)

21

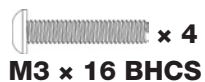

PROTRAC BAG

Rear Shock Tower to Chassis

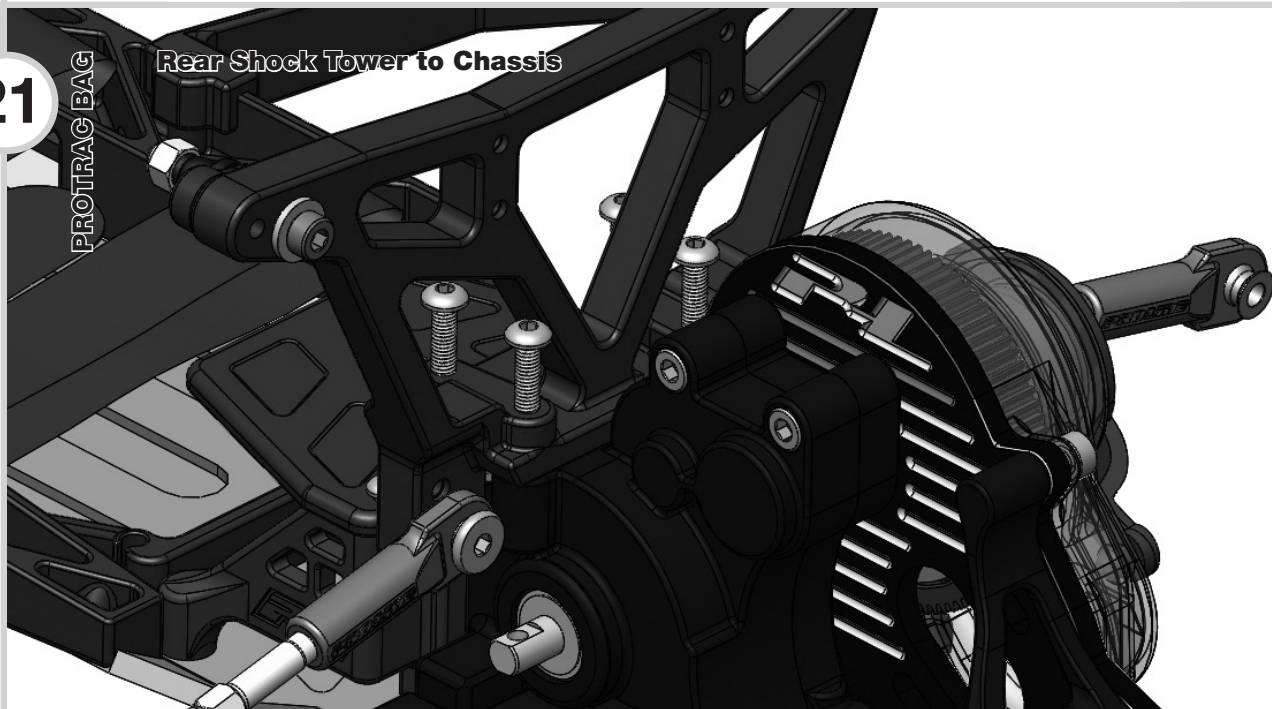





HARDWARE USED
(ACTUAL SIZE)

22

HELMET BAG & BAG D

Rear Body Mount to Shock Tower

-  **x 4**
M2.5 x 12 SHCS
-  **x 1**
Black O-Ring
-  **x 1**
M4 x 12 Setscrew
-  **x 1**
Secure-Loc Cap

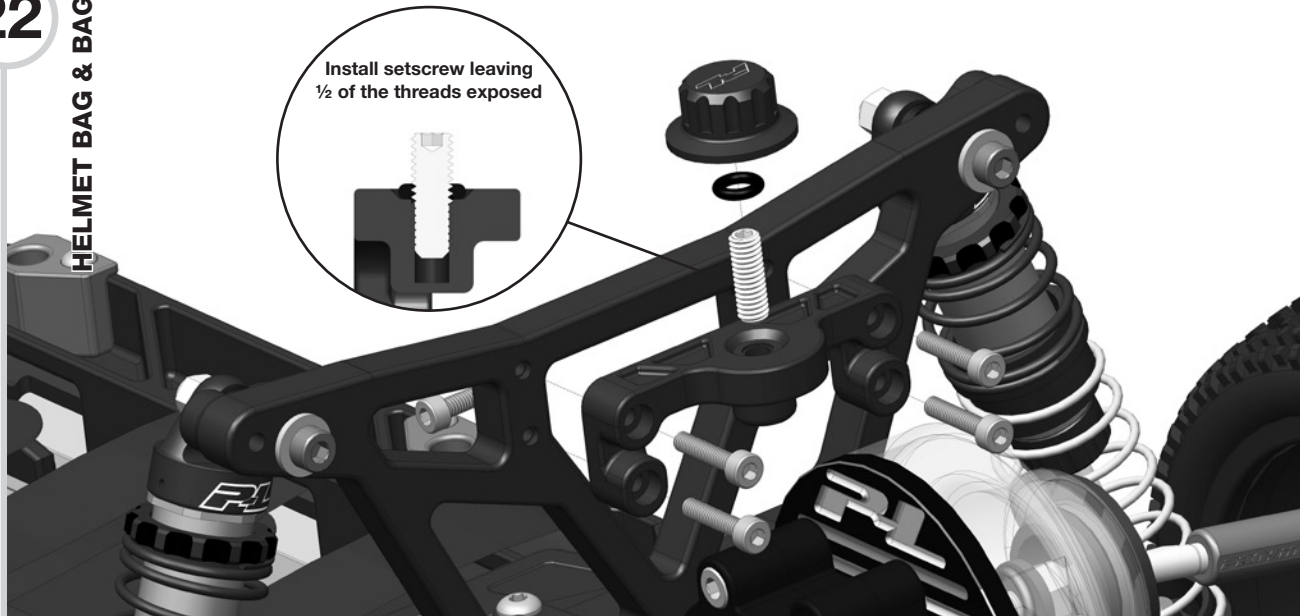

HARDWARE USED
(ACTUAL SIZE)

23

BAG I

Outdrives to Transmission

-  **x 2**
M3 x 10 Setscrew
- Outdrives x 2**

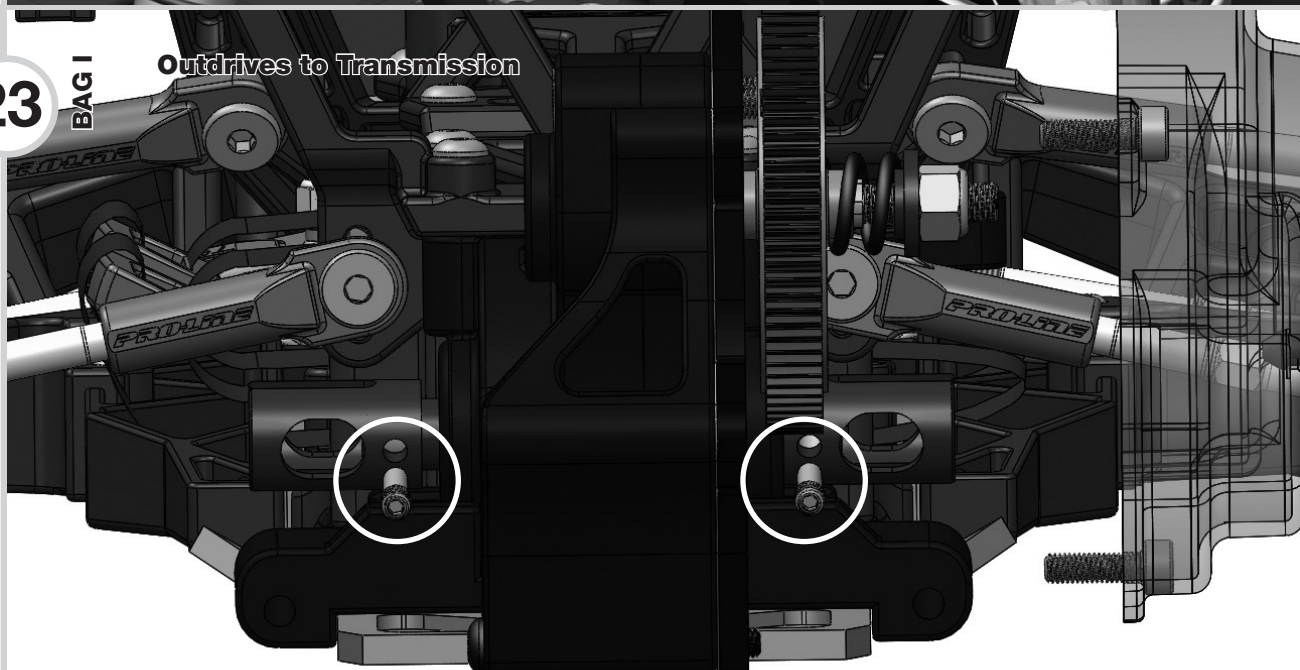

HARDWARE USED
(ACTUAL SIZE)

24

BAG I

Driveshaft Assembly

-  **x 2**
Drive Pin
-  **x 2**
Drive Pin Cup
-  **x 2**
M3 Set Screw
-  **x 2**
Retainer Clip
- Axle x 2**
- Shaft x 2**

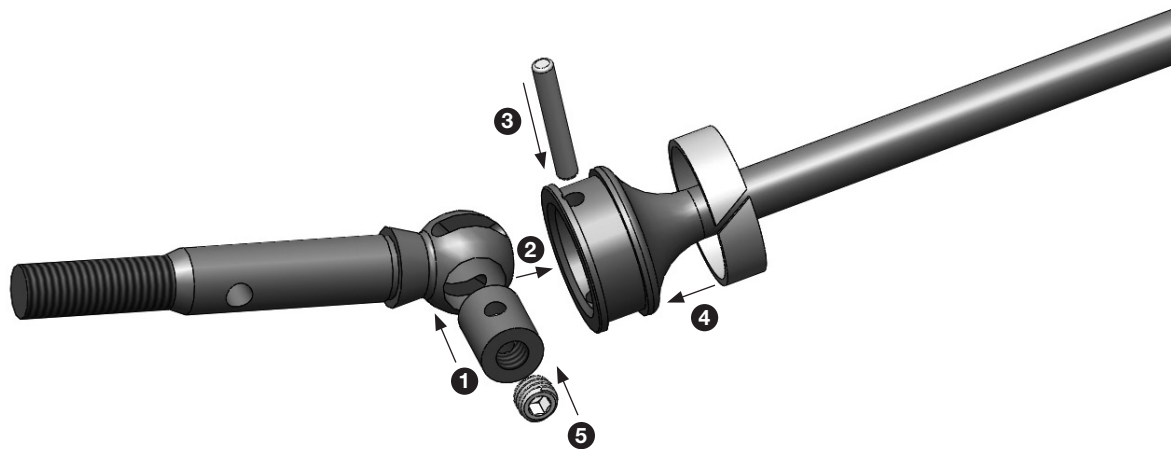





REPEAT THIS STEP FOR OPPOSITE SIDE

HARDWARE USED
(ACTUAL SIZE)

25

**BAG F, I &
PROTRAC BAG**

Rear Arms & Hub Carriers Assembly

-  x 4
5 x 11 Bearing
-  x 2
Rear Outer Hinge Pin
(Bag F)
-  x 2
Rear Inner Hinge Pin
(Bag F)
-  x 4
M3 Locknut
(Bag F)

LOWER HOLE





REPEAT THIS STEP FOR OPPOSITE SIDE

HARDWARE USED
(ACTUAL SIZE)

26

BAG I & J

Rear Wheels Hex & Camber Link Assembly

-  x 2
Cross Pin
(Bag I)
-  x 4
5 x 8 x 0.25 Shims
(Bag I)
-  x 2
Serrated Locknut
(Bag I)
-  x 2
M1.6 x 6 SHCS
(Bag J)
-  x 2
M3 x 16 BHCS
(Bag I)

UPPER MIDDLE HOLE

SHIMS BETWEEN BEARING AND PIN

REPEAT THIS STEP FOR OPPOSITE SIDE

27

Remove Rear Motor Guard

REMOVE SCREW
(NO LONGER NEEDED)

REMOVE SCREW
(SAVE FOR STEP 30)

REMOVE GUARD
(NO LONGER NEEDED)

REMOVE SCREW
(NO LONGER NEEDED)

HARDWARE USED
(ACTUAL SIZE)

28

Rear Bumper to Chassis

BUMPER BAG

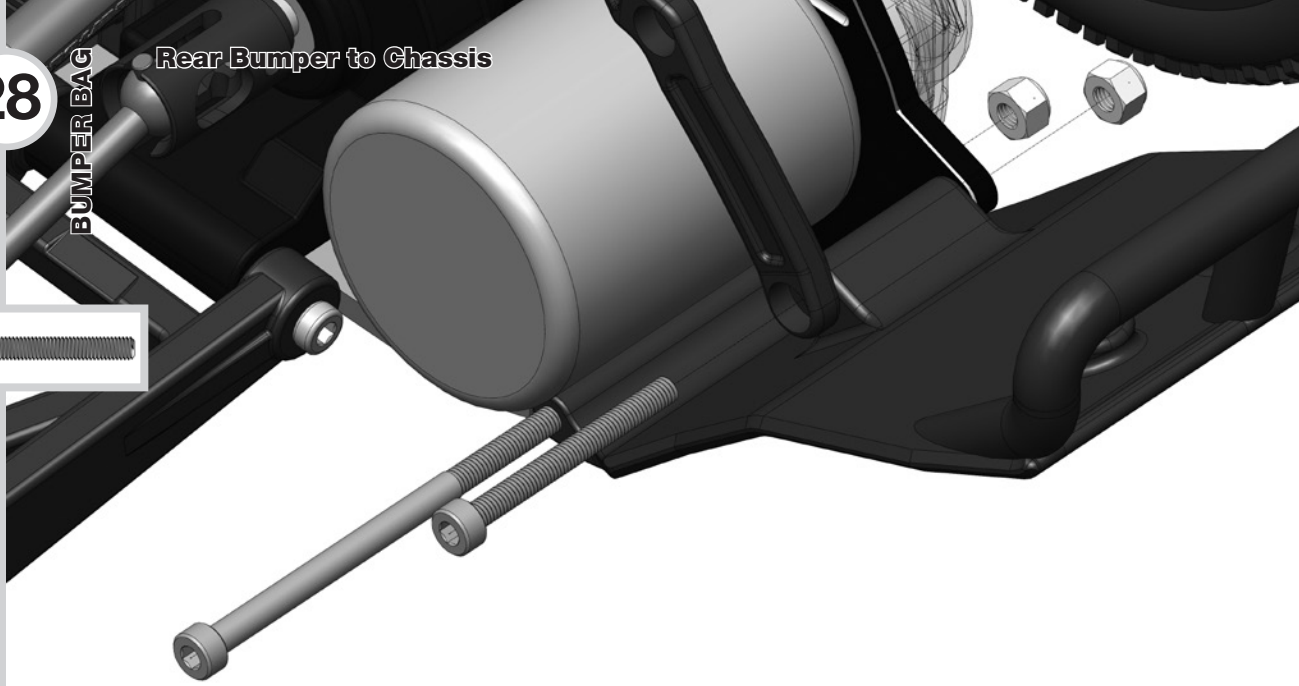
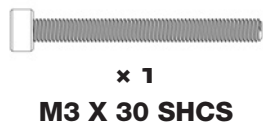

HARDWARE USED
(ACTUAL SIZE)

29

Rear Bumper Brace to Transmission

BUMPER BAG

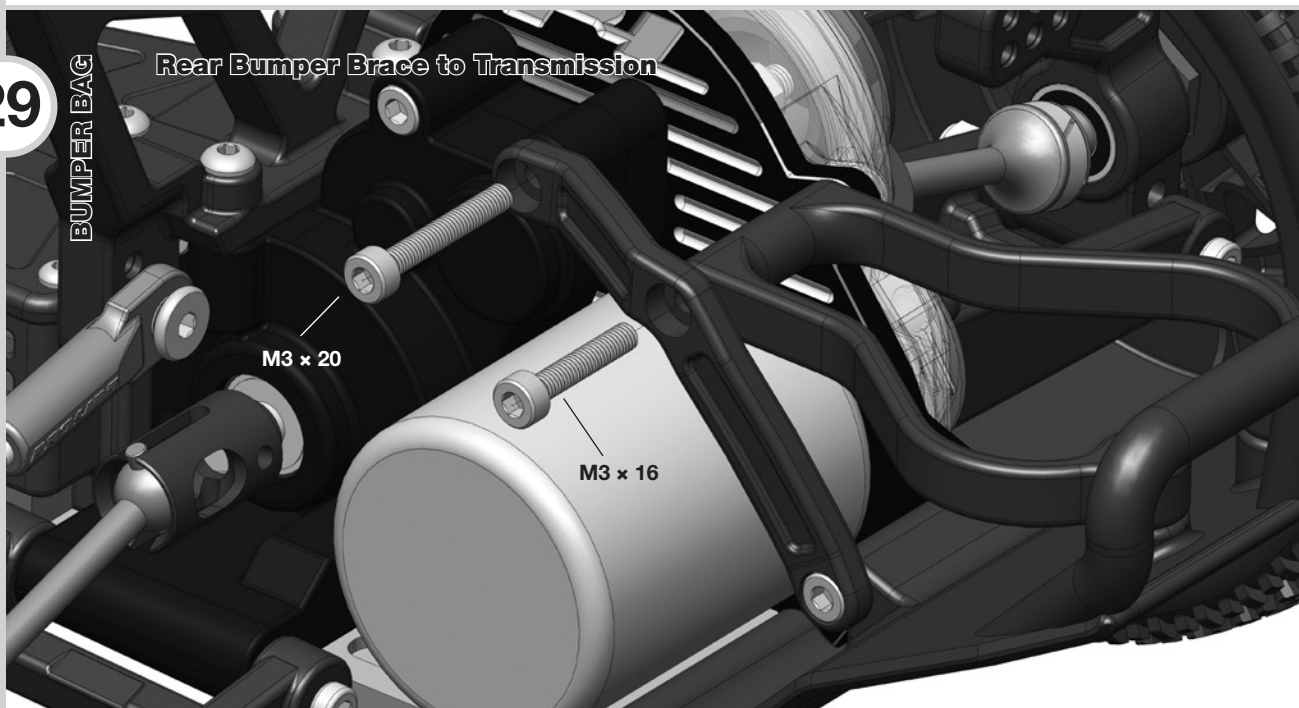
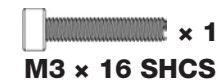

HARDWARE USED
(ACTUAL SIZE)

30

Rear Bumper Brace to Bumper

BUMPER BAG



Reinstall gear cover
with screws from
Step 27

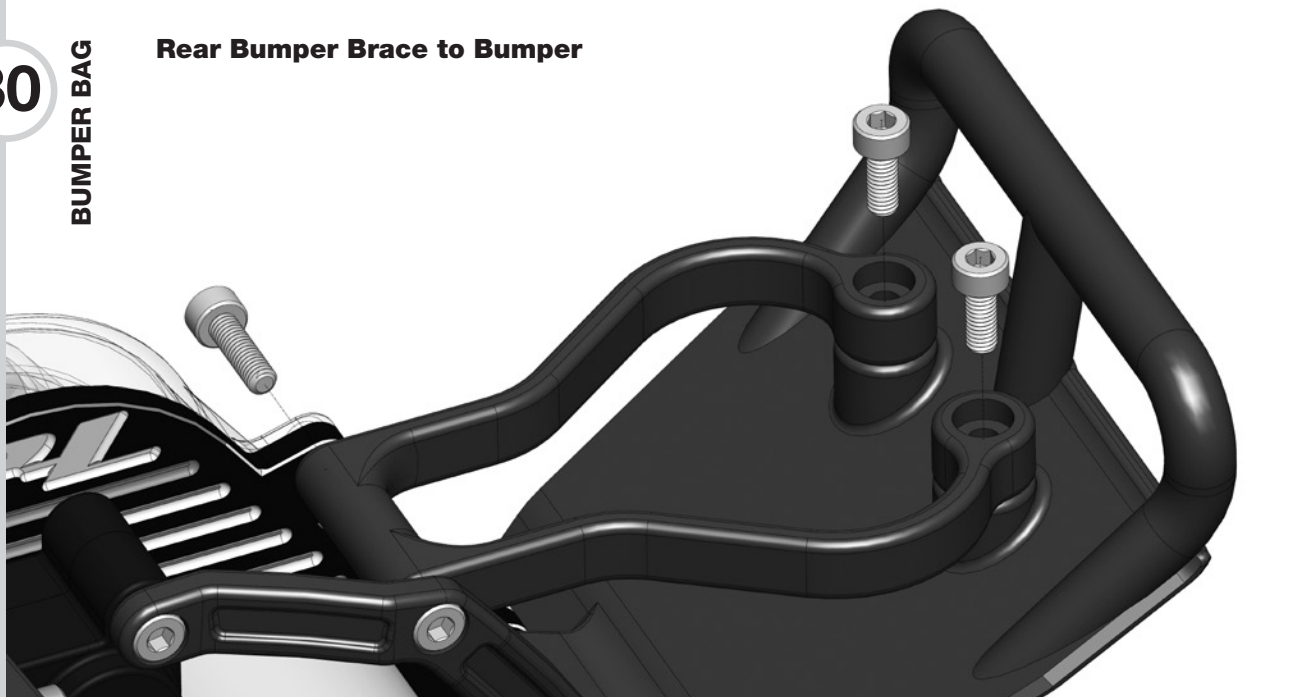

31

Shock Setup (Fluids Bag)

1. Remove Springs
 2. Fill with oil
 3. Bleed
 4. Tighten
 5. Replace Springs
- x 4

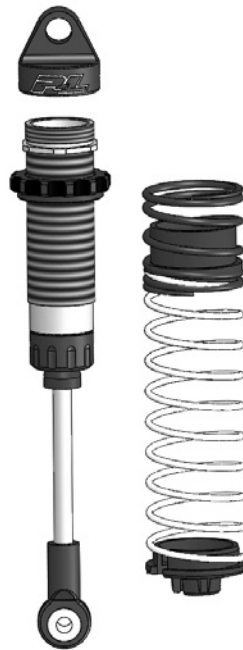

Visit
prolineracing.com/pro-2/build
 for shock assembly videos
 and spring rate charts.

HARDWARE USED (ACTUAL SIZE)

32

BAG C

Install Rear Shocks

 x 2
 M3 x 16 BHCS

Use M3 Locknuts
 installed on Step 18

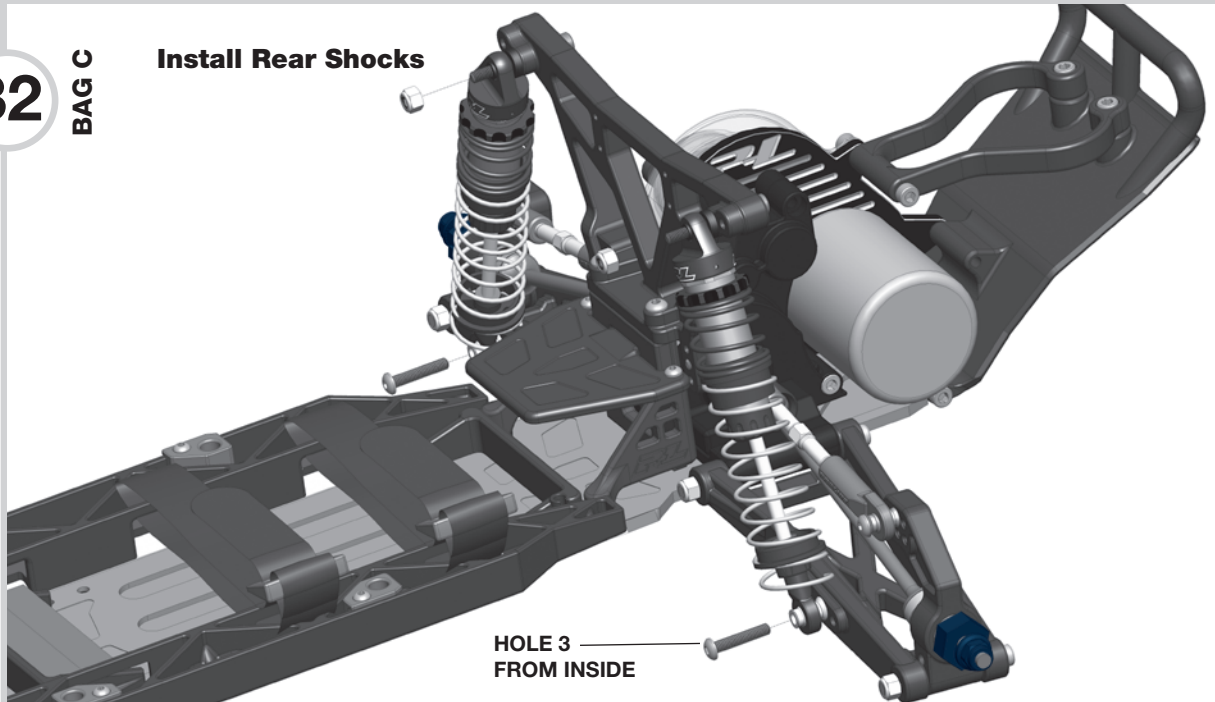

HARDWARE USED (ACTUAL SIZE)

33

BAG C

Install Front Shocks

 x 2
 M3 x 16 BHCS

Use M3 Locknuts
 installed on Step 4

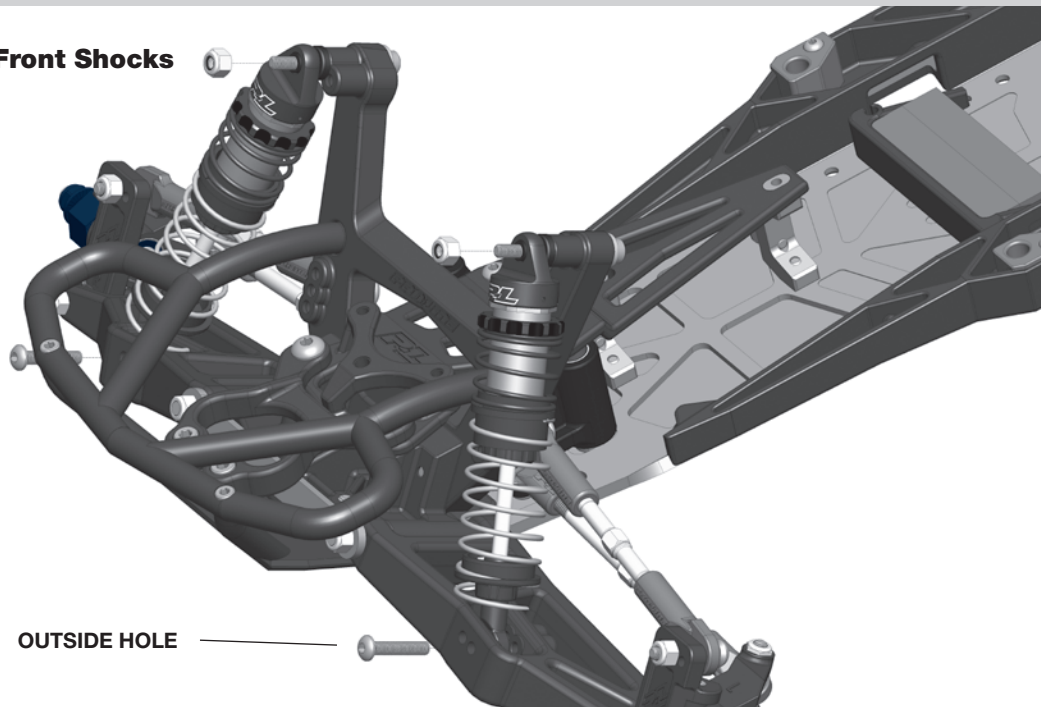

HARDWARE USED
(ACTUAL SIZE)

34

BAG L & E

Front Arms & Hinge Pin Brace to Bulkhead

Steering Rod



2" (ACTUAL SIZE)

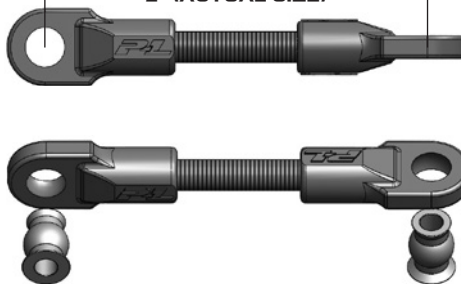

HARDWARE USED
(ACTUAL SIZE)

35

BAG L

Install Servo

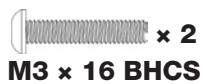

1. Remove (4) screws in Servo Mount
2. Loosen (2) screws in Steering Rack
3. Install Servo
4. Tighten all screws
5. Zero out at vertical
6. Align link straight with spacers

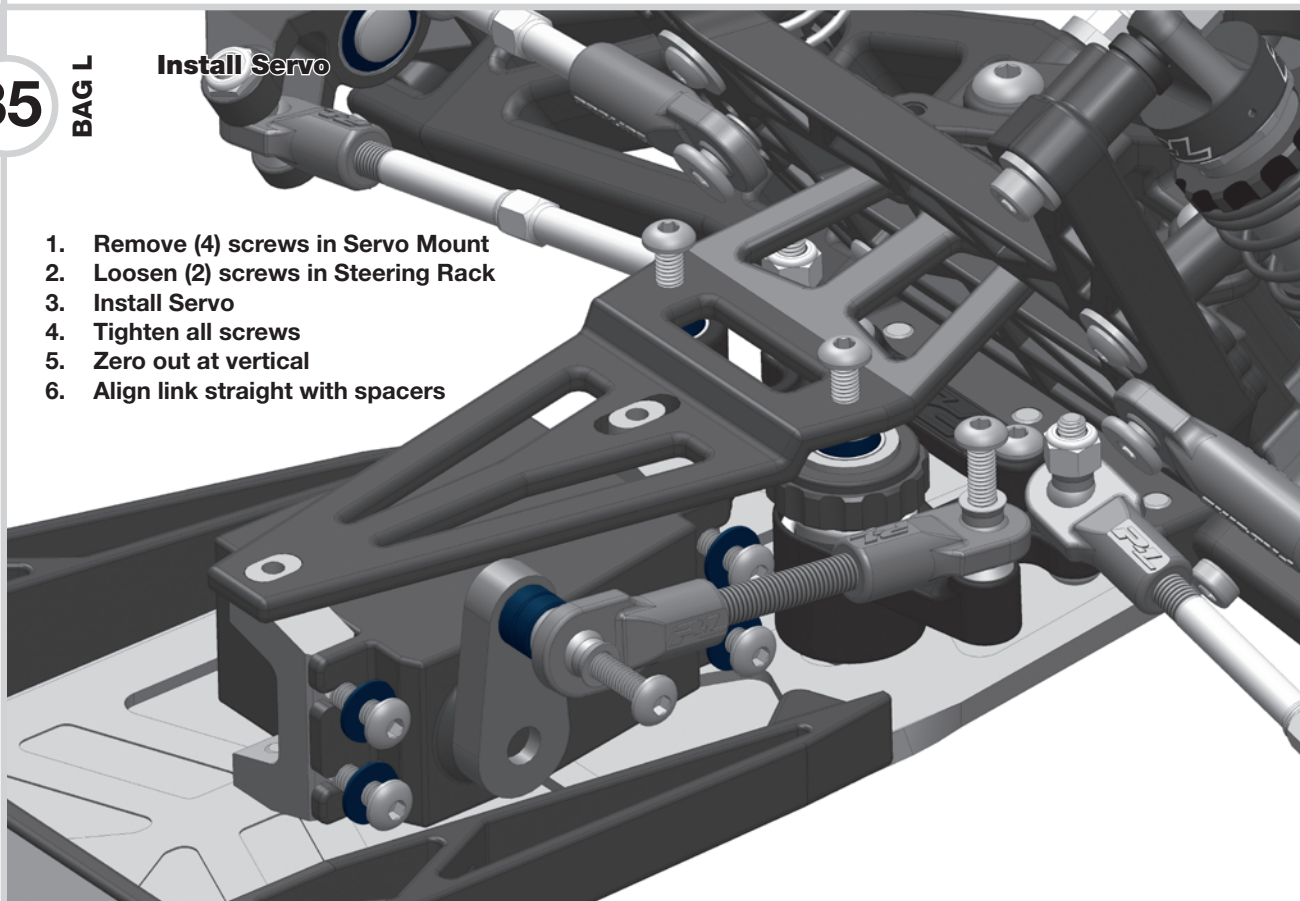

HARDWARE USED
(ACTUAL SIZE)

36

HELMET BAG

Front Body Mount



Install setscrew leaving 1/2 of the threads exposed

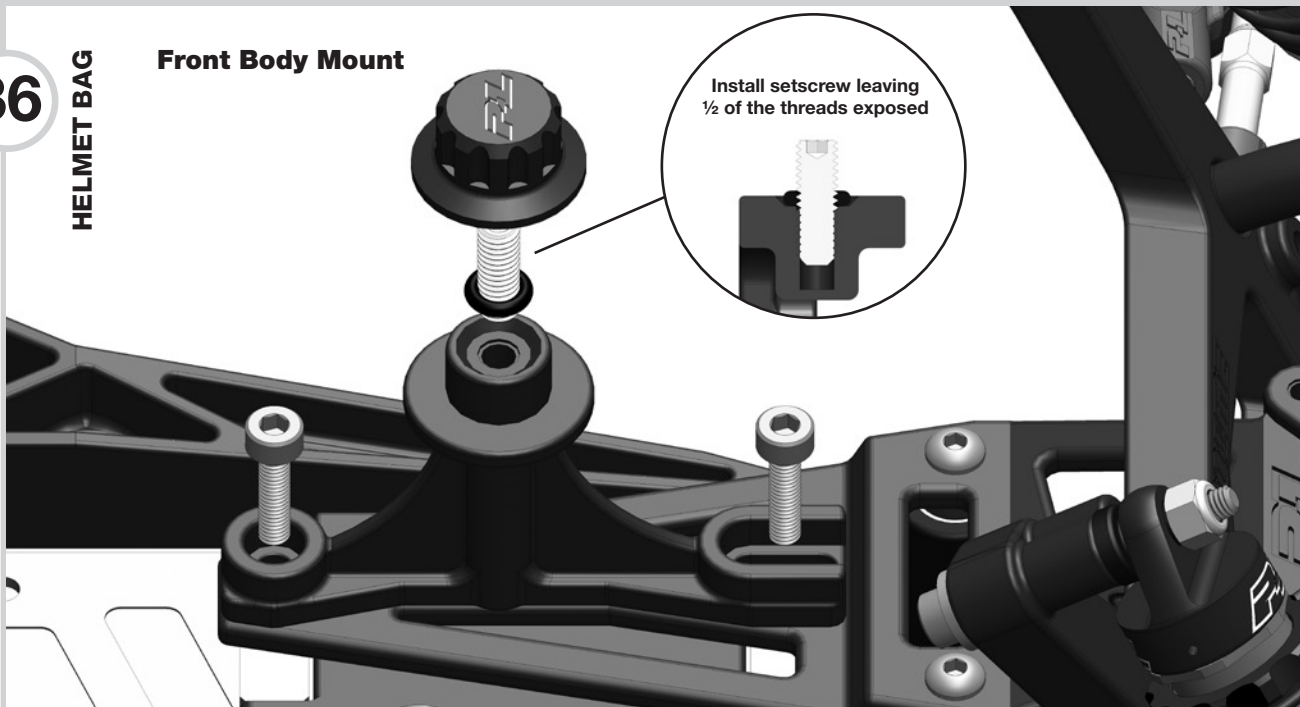

HARDWARE USED
(ACTUAL SIZE)

37

BAG L

Motor Installation

 x 2
M3 x 8 SHCS

 x 2
HD Motor Washer

1. Remove Gear Cover
2. Install Motor
3. Set Gear Mesh (Pinion sold separately)
4. Reinstall Gear Cover

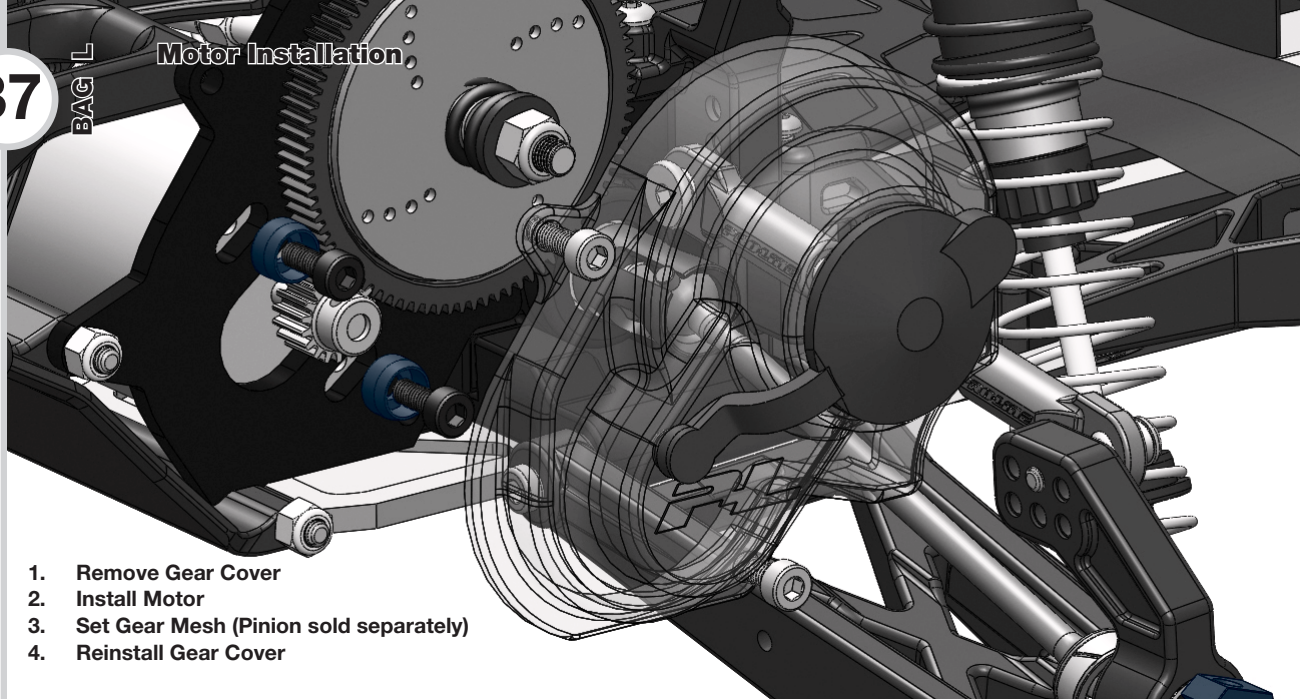

38

TIRE BAG

Install Pre-Mounted Blockade Tires (PL #1183-25)

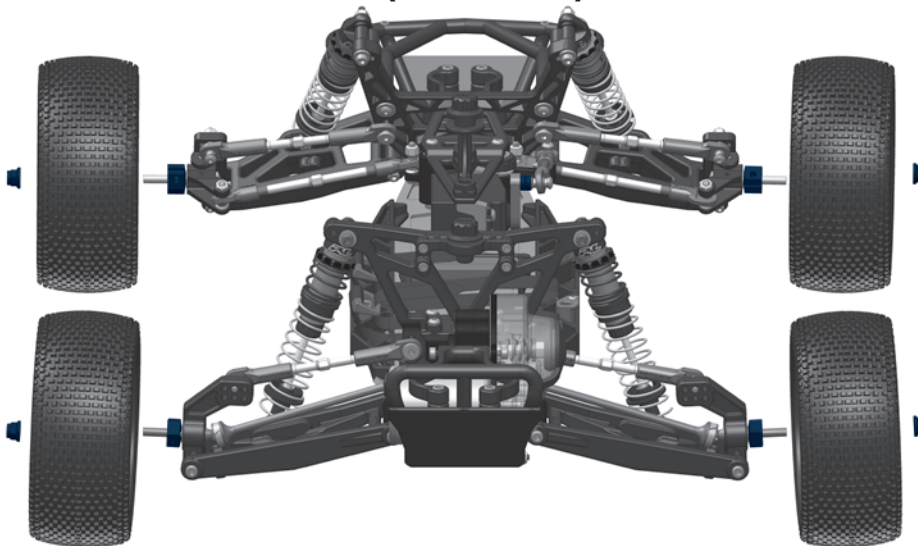

See our full line of
Pre-mounted SC Tires
by scanning this QR code.

HARDWARE USED
(ACTUAL SIZE)

39

CAGE BAG

Window Nets to Cage

 x 8
M2.5 x 6 BHCS

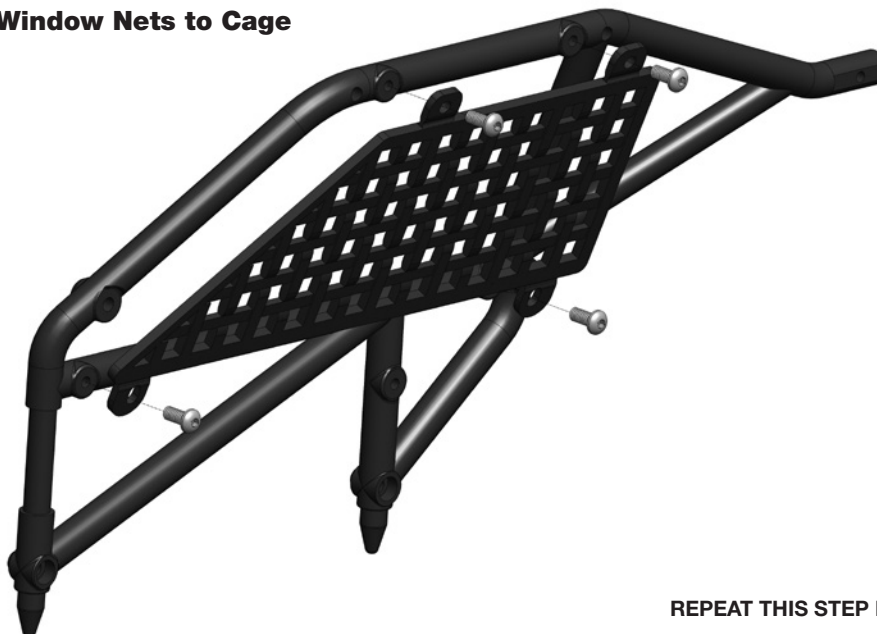

REPEAT THIS STEP FOR OPPOSITE SIDE

HARDWARE USED
(ACTUAL SIZE)

40

CAGE BAG

Roof & Nose Brace to Cage

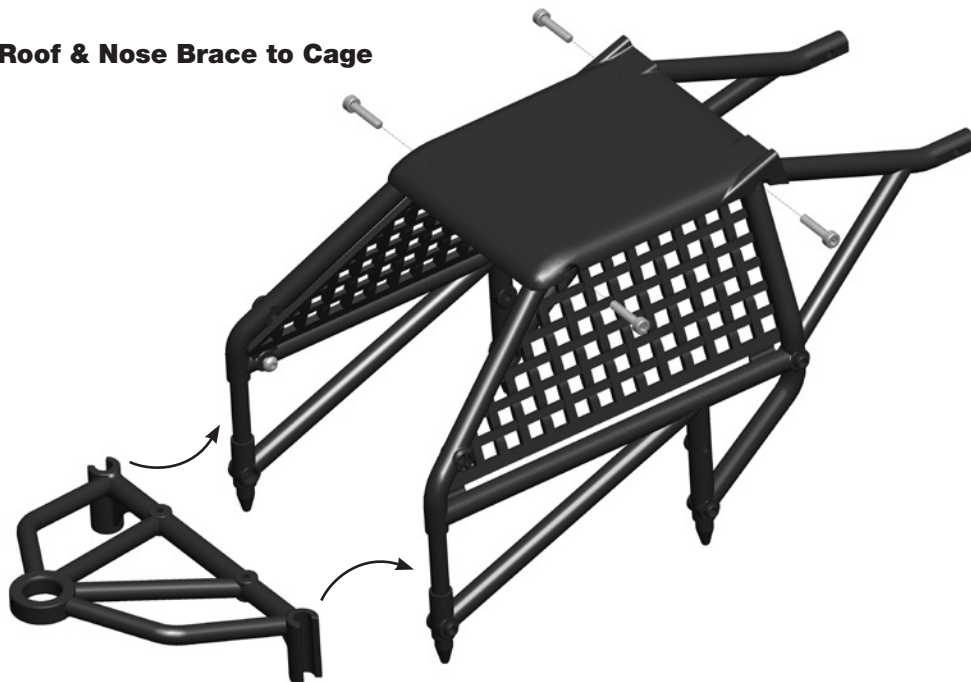

 **x 4**
M2.5 x 12 SHCS

HARDWARE USED
(ACTUAL SIZE)

41

BAG A

Rear Cage Assembly

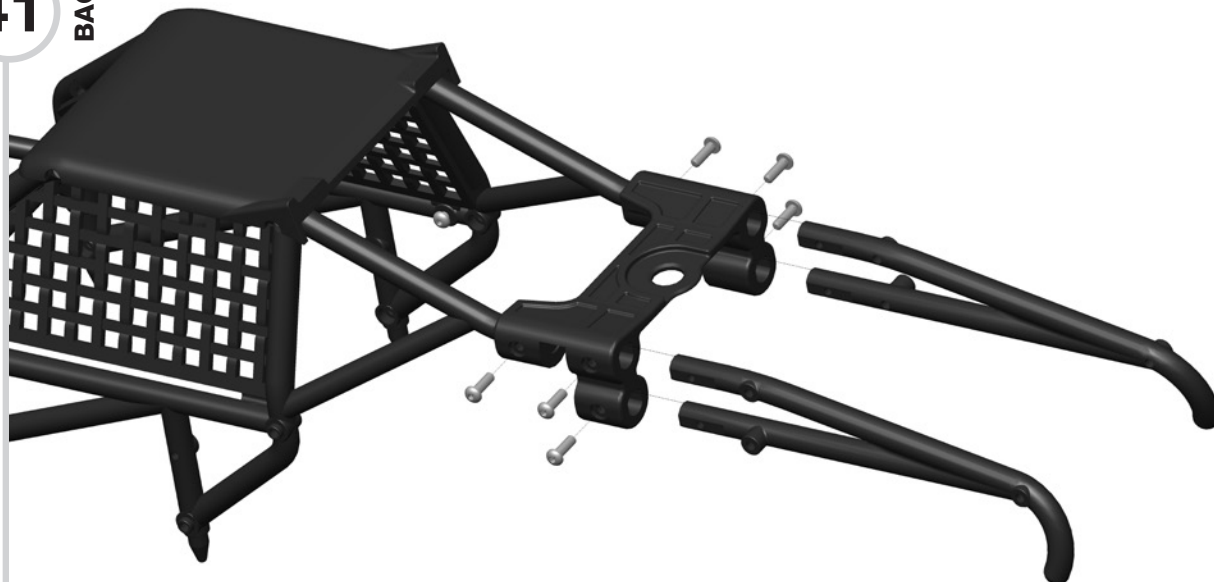

 **x 6**
M2.5 x 8 BHCS

HARDWARE USED
(ACTUAL SIZE)

42

HELMET BAG

Rear Cage Assembly Cont'd

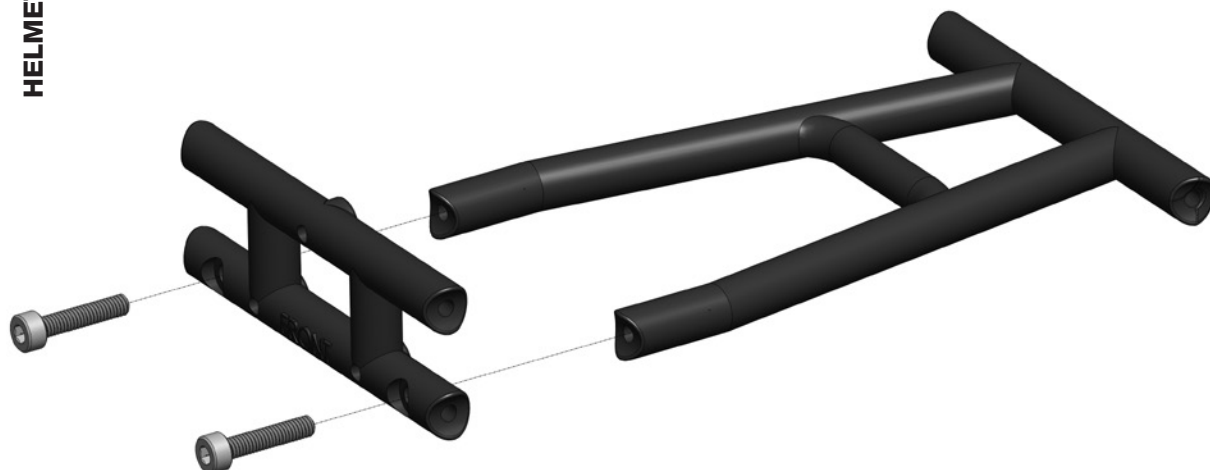

 **x 2**
M2.5 x 12 SHCS

43 Paint & Trim your PRO-2 SC Buggy Body.

Visit prolinerracing.com/how-to-tips for body painting tips.



HARDWARE USED
(ACTUAL SIZE)

 x 6
M2.5 x 14 BHCS

44

HELMET BAG

Attach Side Panels

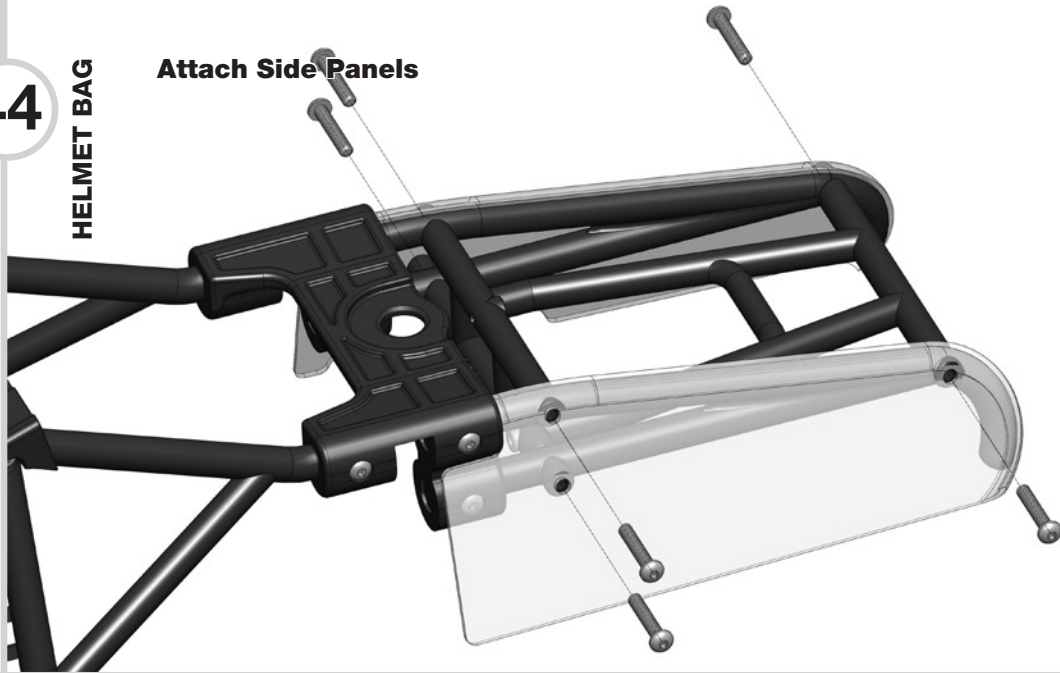

HARDWARE USED
(ACTUAL SIZE)

 x 1
M3 x 12 SHCS

Plastic washer
from parts tree

45

HELMET BAG

Mount Helmet

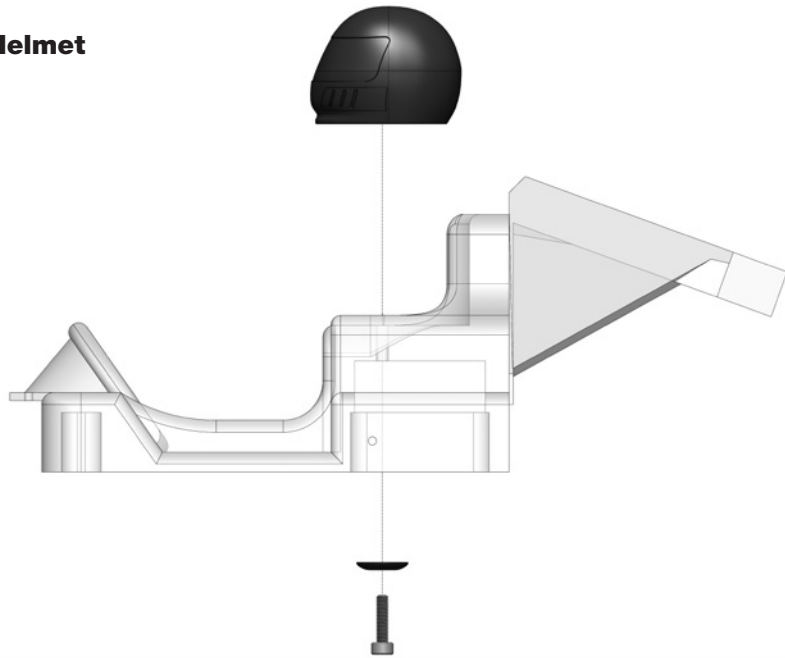

HARDWARE USED
(ACTUAL SIZE)

 x 2
M2.5 x 6 BHCS

46

CAGE BAG

Painted interior to Cage - Front



HARDWARE USED
(ACTUAL SIZE)

47

CAGE BAG

Painted interior to Cage - Rear

 × 2
M2.5 × 6 BHCS

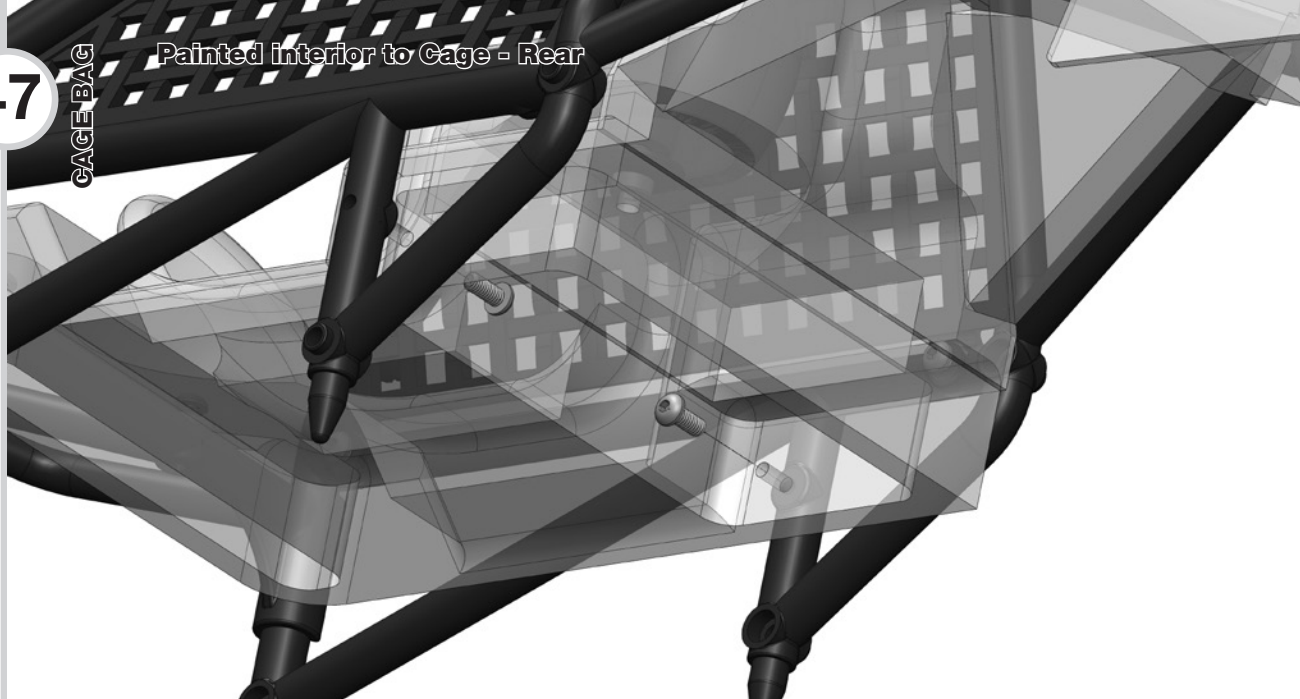

48

Trim & mount painted PRO-2 Buggy Body

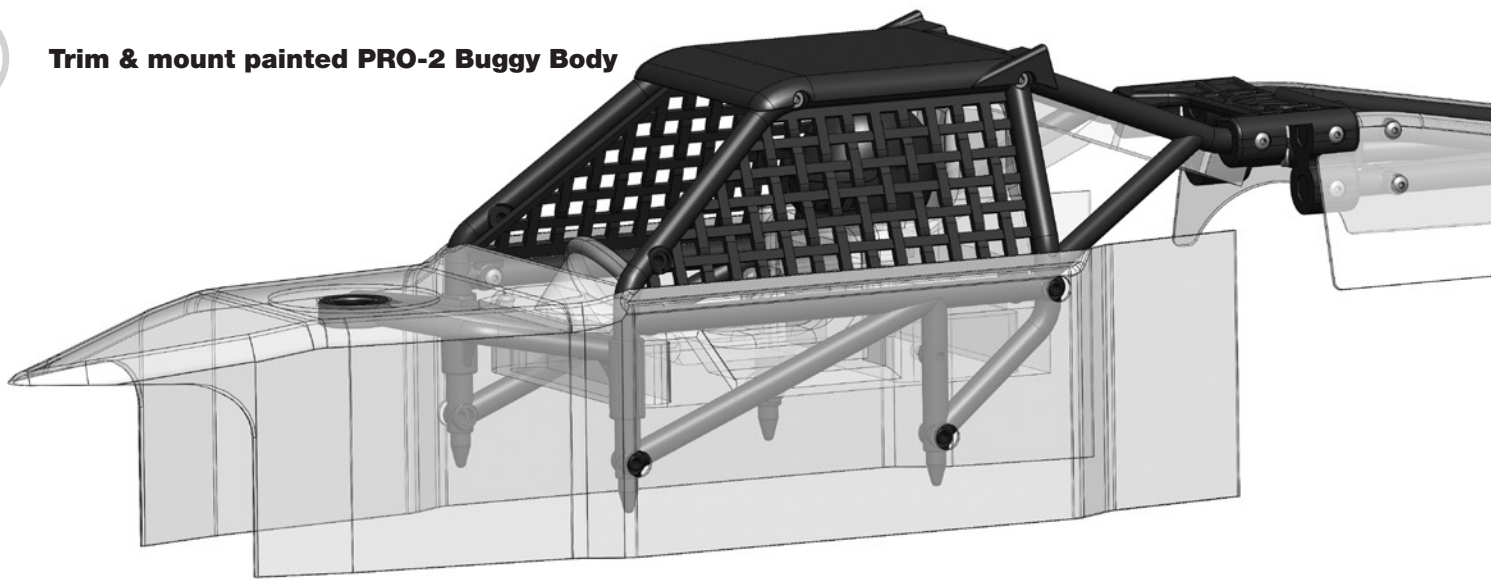

HARDWARE USED
(ACTUAL SIZE)

49

CAGE BAG

Nerf Bars to Cage

 × 6
M2.5 × 12 SHCS

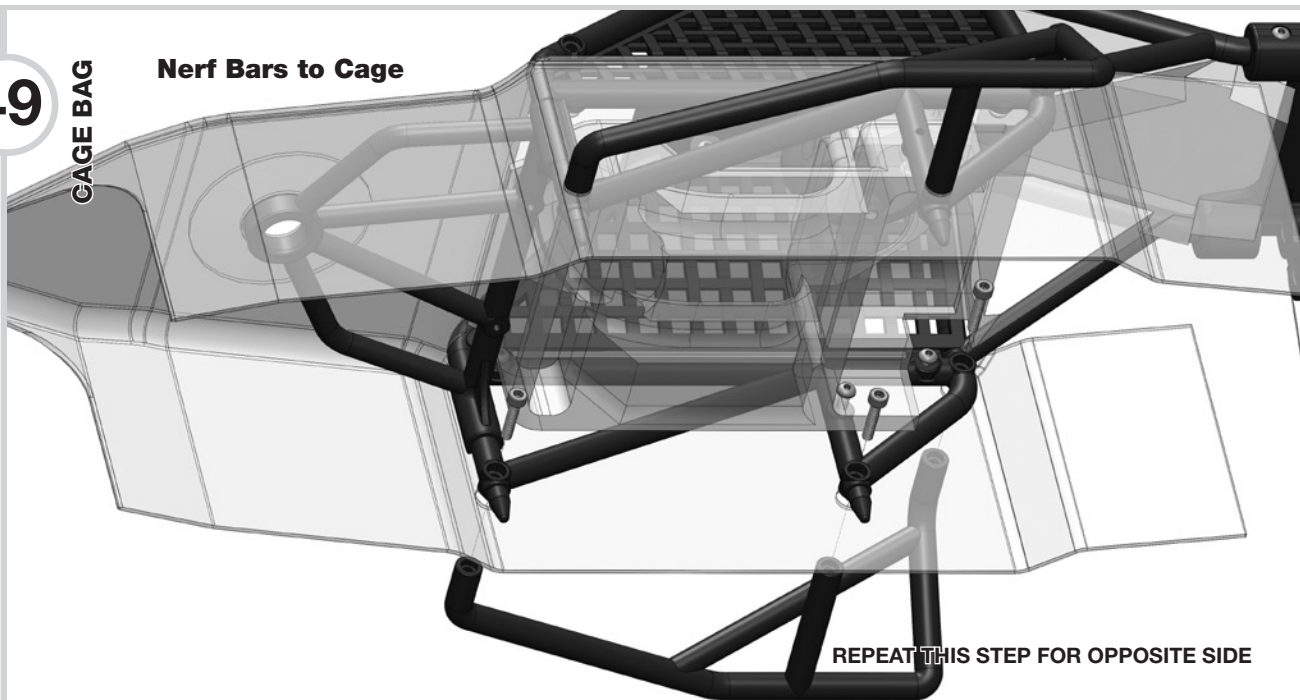

REPEAT THIS STEP FOR OPPOSITE SIDE

50

Remove Truck Nerf Bars



REPEAT THIS STEP FOR OPPOSITE SIDE

HARDWARE USED
(ACTUAL SIZE)

51

Install Buggy Body Holders

× 4
M2.5 × 6 BHCS

CAGE BAG

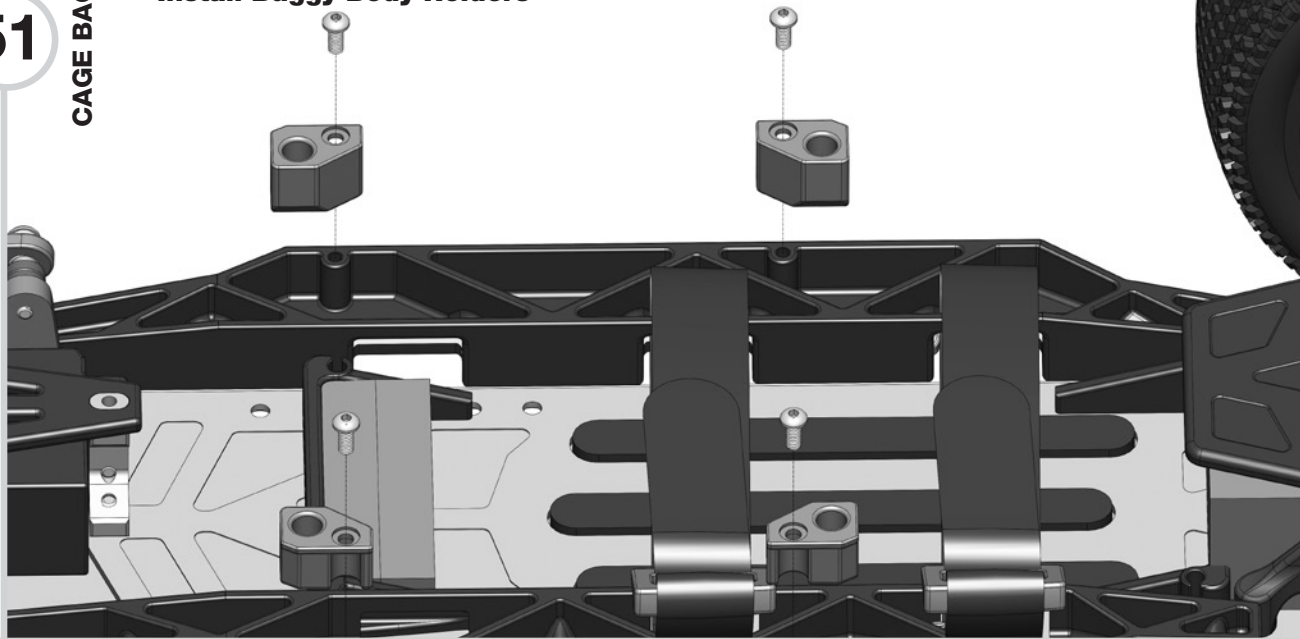

52

Electronics Placement

FOAM BAG

ELECTRONICS (Not Included)

ANTENNA TUBE

RECEIVER (Not Included)

FOAM STRIPS

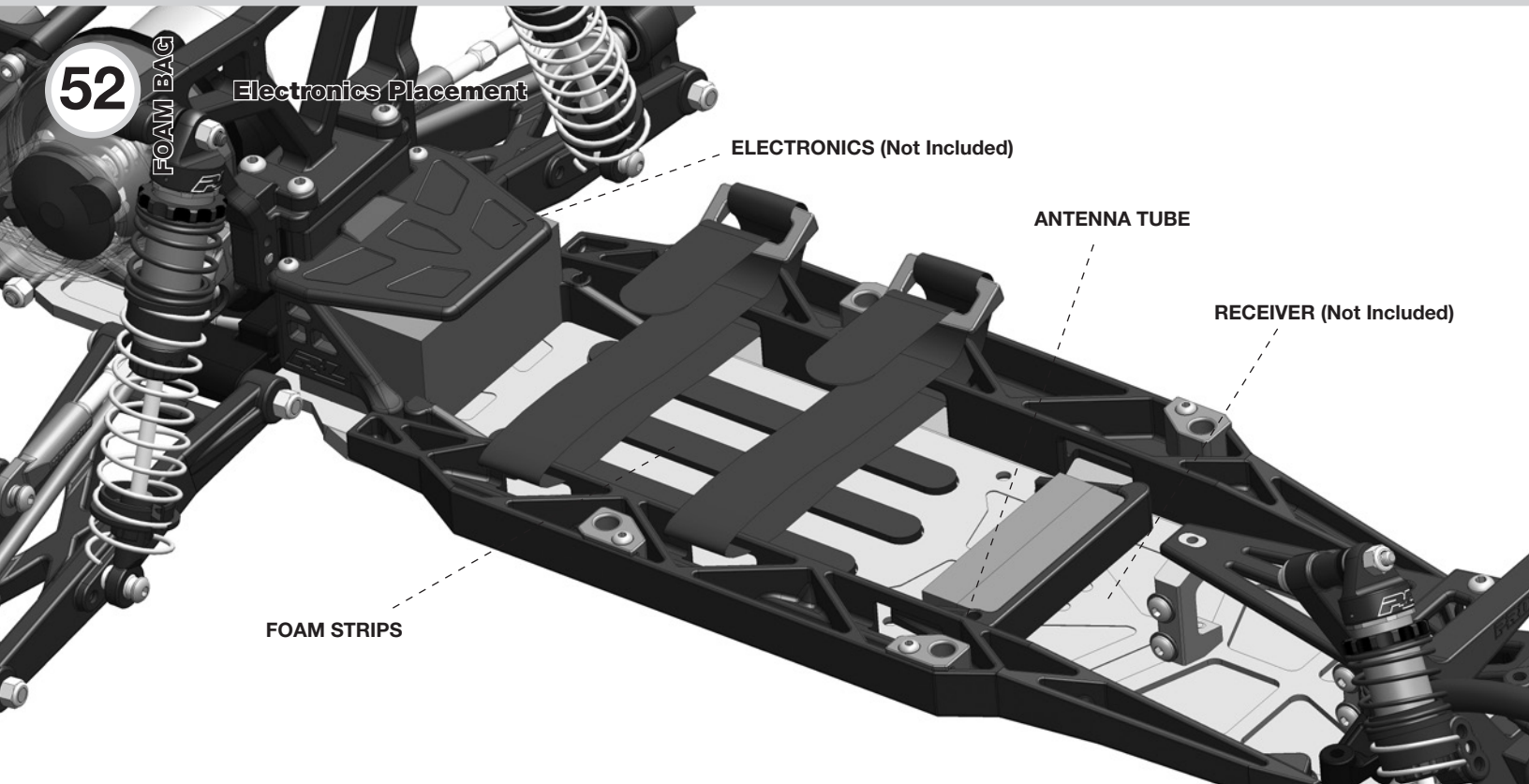

OPTIONAL STEPS

HARDWARE USED
(ACTUAL SIZE)

53

CAGE BAG

Light Mounts – Requires #6085-00 (Sold Separately)



× 2

M2.5 × 10 BHCS

M3 x 6 Wood screws
(included with lights)
× 2



REPEAT THIS STEP FOR OPPOSITE SIDE

HARDWARE USED
(ACTUAL SIZE)

54

CAGE BAG

Light Mounts – Requires #6085-00 (Sold Separately)



× 2

M2.5 × 10 BHCS

M3 x 6 Wood screws
(included with lights)
× 4



HARDWARE USED
(ACTUAL SIZE)

55

CAGE BAG & HELMET BAG

Wing Mount – Requires 1:10 Buggy Wing (Sold Separately)



× 3

M2.5 × 12 SHCS



× 2

M3 × 8 BHCS

Plastic washers from
parts tree × 2



See our full line of 1:10 Buggy wings
by scanning this QR code.



SCAN

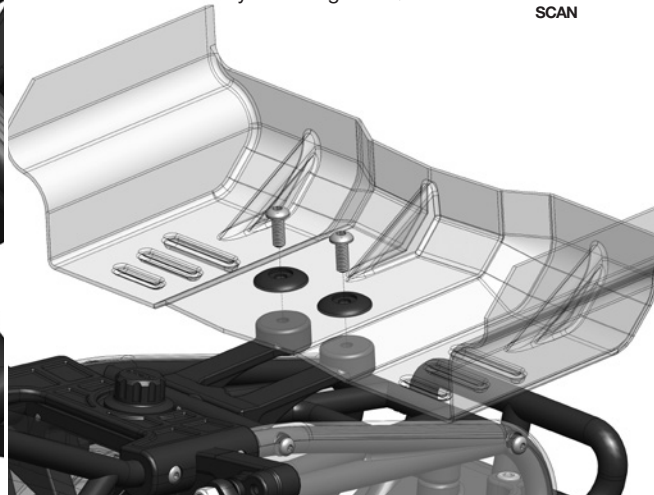



PRO-2 Buggy Kit Replacement Parts

6092-00 Performance Transmission 6092-01 Transmission Plastics 6092-02 Gear Cover & Plug 6092-03 Motor Plate 6092-04 Transmission Hardware 6092-05 Diff Housing & Idler Gear 6092-06 Diff Internal Gears 6092-07 86T Spur Gear (Stock) 6092-08 Diff Seal Kit 6092-09 Top Shaft & Slipper Plates 6092-10 Slipper Pads 6092-11 Ball Bearings	6093-00 PRO-2 LCG Chassis 6093-01 Chassis Replacement 6093-03 Internal Plastics 6093-04 Servo Mounts & Hardware 6093-05 Steering Posts & Hardware	6092-16 HD Motor Washers 6092-16 HD Motor Washers
		6100-00 4mm Serrated Wheel Nuts 6100-00 4mm Serrated Wheel Nuts
	6062-00 ProTrac Suspension Kit 6062-01 Front Arms 6062-02 Rear Arms 6062-04 Rear Shock Tower 6062-05 Rear Hub Carriers 6062-06 Camber Links (2) 6062-07 Steering Links (2)	1183-25 Blockade M3 on F-11 Wheels 1183-25 Blockade M3 on F-11 Wheels
		6096-00 PRO-2 Hinge Pin Set 6096-00 PRO-2 Hinge Pin Set
		6099-00 PRO-2 ProTrac Axle Kit 6099-00 PRO-2 ProTrac Axle Kit
6063-00 Power Stroke Shocks (Front) 6063-02 Shock Rebuild Kit 6063-03 Front Spring Assortment Kit 6063-05 Mounting Hardware 6063-06 Front Shaft Replacment (2)	6067-00 Performance Steering Kit 6067-00 Performance Steering Kit	6095-00 PRO-2 Front Bumper & Bulkhead 6095-00 PRO-2 Front Bumper & Bulkhead
	6070-00 Extended Body Mount Kit 6070-02 Thumbwashers & Hardware	6097-00 PRO-2 Front Clamping Hex 6097-00 PRO-2 Front Clamping Hex
6063-01 Power Stroke Shocks (Rear) 6063-02 Shock Rebuild Kit 6063-04 Rear Spring Assortment Kit 6063-05 Mounting Hardware 6063-07 Rear Shaft Replacment (2)	6102-00 Pivot Ball & Rod End Set 6102-00 Pivot Ball & Rod End Set	6098-00 PRO-2 Rear Clamping Hex 6098-00 PRO-2 Rear Clamping Hex
	6104-00 Front Hinge Pin Brace 6104-00 Front Hinge Pin Brace	6099-10 PRO-2 Replacement Outdrives 6099-10 PRO-2 Replacement Outdrives
6101-00 PRO-2 Front Hub Kit 6101-01 Front Hub Plastics 6101-02 Steel King Pins (4)	6254-00 PRO-2 Performance Buggy Conv. Kit 6254-01 Cage, Roof & Front Shock Tower Plastics 6254-02 Rear Engine Cover Plastics, Cage Mounts, Helmet 6254-03 Front and Rear Bumper Plastics, Light Mounts 3407-00 PRO-2 SC Buggy Body	6070-02 Body Mount Secure-Loc Cap Kit 6070-02 Body Mount Secure-Loc Cap Kit

Optional Parts

6092-12 Optional Anti-Squat Blocks 6092-12 Optional Anti-Squat Blocks	6092-15 Optional 82T Spur Gear 6092-15 Optional 82T Spur Gear	6308-00 Pro-Spec Shocks (Front) 6308-30 Pre-Assembled (Front)
6092-13 Optional 78T Spur Gear 6092-13 Optional 78T Spur Gear	6085-00 Light Bar Kit 6085-00 Light Bar Kit	6308-01 Pro-Spec Shocks (Rear) 6308-31 Pre-Assembled (Rear)
6092-17 MIP Super Ball Diff Kit 6092-17 MIP Super Ball Diff Kit	Go To ProLineRacing.com for the latest Tires, Wheels, & Accessories for your PRO-2 SC Buggy!	

TRACK: Stock PRO-2 Buggy Setup
 EVENT: _____
 DRIVER: _____ DATE: _____
 QUAL: _____ FINISH: _____



SC BUGGY SETUP SHEET

FRONT PROTRAC SUSPENSION

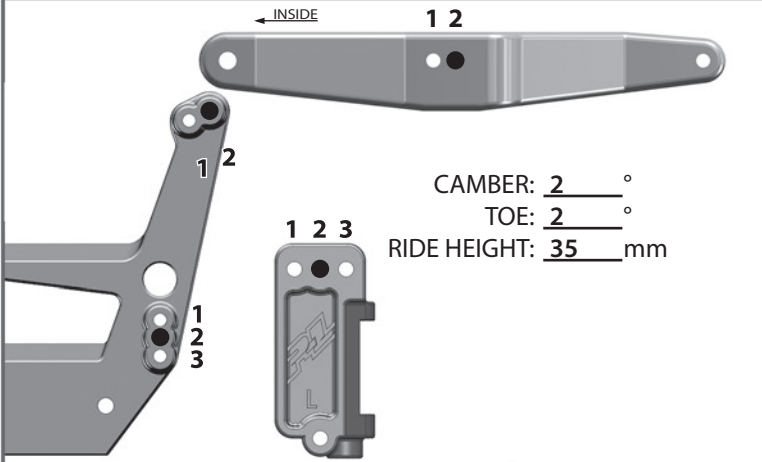

CAMBER: 2 °
 TOE: 2 °
 RIDE HEIGHT: 35 mm

POWERSTROKE FRONT SHOCKS

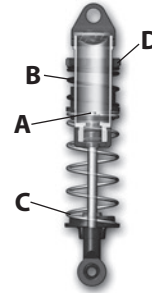

(A) PISTON: Stock
 OIL WEIGHT: 35 wt
 (B) PRIMARY SPRING: Yellow
 (C) SECONDARY SPRING: Green
 DROOP SPACER: _____ mm
 COMPRESSION SPACER: _____ mm
 (D) SPRING ADJUSTMENT: _____ mm

REAR PROTRAC SUSPENSION

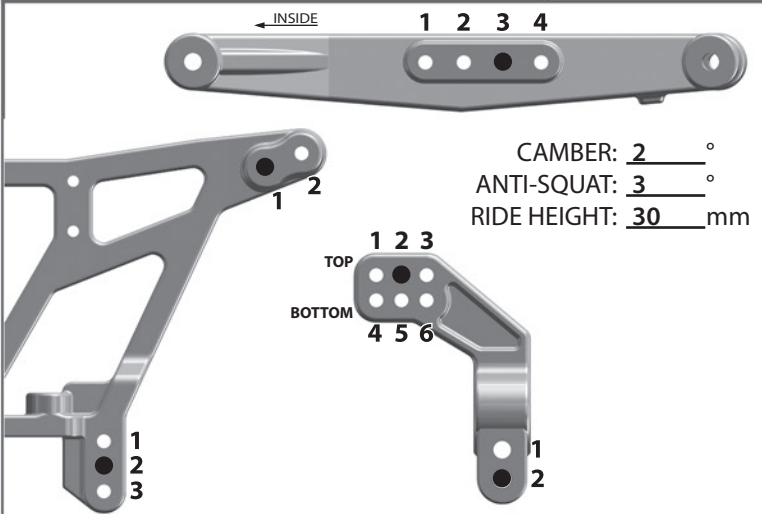

CAMBER: 2 °
 ANTI-SQUAT: 3 °
 RIDE HEIGHT: 30 mm

POWERSTROKE REAR SHOCKS

(A) PISTON: Stock
 OIL WEIGHT: 35 wt
 (B) PRIMARY SPRING: Yellow
 (C) SECONDARY SPRING: Green
 DROOP SPACER: _____ mm
 COMPRESSION SPACER: _____ mm
 (D) SPRING ADJUSTMENT: _____ mm

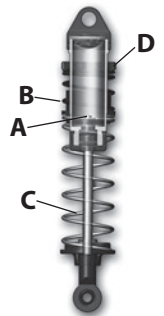

ELECTRONICS

MOTOR: _____
 ESC: _____
 RECEIVER: _____
 SERVO: _____
 RADIO: _____

BATTERY PLACEMENT

BATTERY: _____
 PLACEMENT: _____

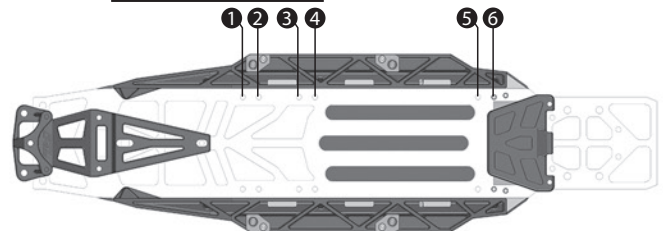

TRACK INFORMATION

TRACTION:	HIGH	MED	LOW
SURFACE:	SMOOTH	BUMPY	BLUE GROOVE
CONDITIONS:	SOFT DIRT	CLAY	WET DUSTY

OTHER: _____

TRANSMISSION SETTINGS

PINION: _____
 SPUR GEAR: Stock 86 tooth
 DIFF. OIL: Stock 5,000 wt.

FRONT TIRES

REAR TIRES

TIRE: <u>Blockade SC</u>	TIRE: <u>Blockade SC</u>
COMPOUND: <u>M3</u>	COMPOUND: <u>M3</u>
INSERT: <u>Closed Cell</u>	INSERT: <u>Closed Cell</u>
WHEEL: <u>F-11 Pro-Trac</u>	WHEEL: <u>F-11 Pro-Trac</u>

NOTES

For complete step-by-step instructions
 visit PROLINERACING.com



TRACK: _____
 EVENT: _____
 DRIVER: _____ DATE: _____
 QUAL: _____ FINISH: _____

PRO-2

SC BUGGY SETUP SHEET

FRONT PROTRAC SUSPENSION

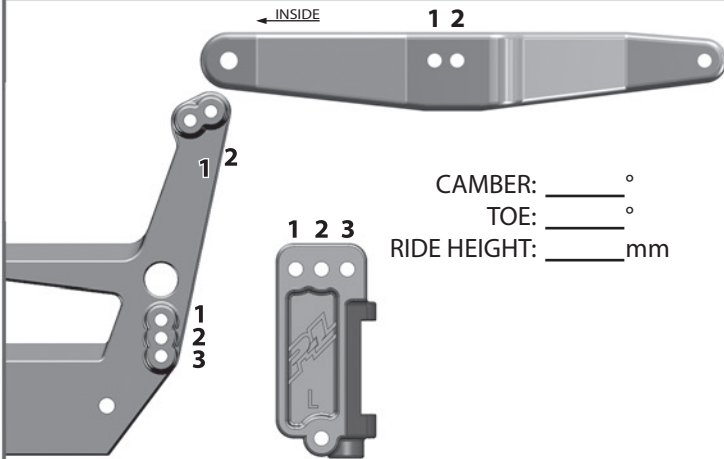

REAR PROTRAC SUSPENSION

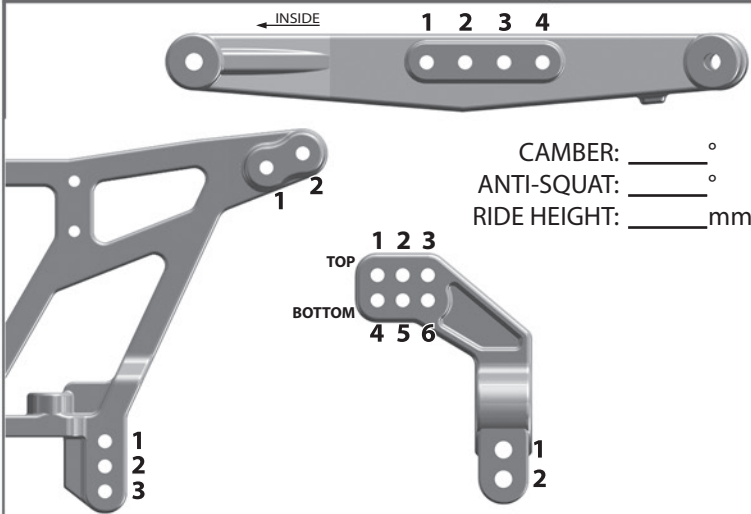

ELECTRONICS

MOTOR: _____
 ESC: _____
 RECEIVER: _____
 SERVO: _____
 RADIO: _____

TRACK INFORMATION

TRACTION:	HIGH	MED	LOW
SURFACE:	SMOOTH	BUMPY	BLUE GROOVE
CONDITIONS:	SOFT DIRT	CLAY	WET DUSTY

OTHER: _____

FRONT TIRES

REAR TIRES

TIRE: _____	TIRE: _____
COMPOUND: _____	COMPOUND: _____
INSERT: _____	INSERT: _____
WHEEL: _____	WHEEL: _____

POWERSTROKE FRONT SHOCKS

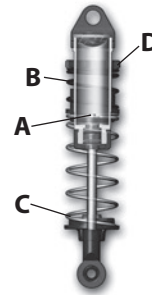

(A) PISTON: _____
 OIL WEIGHT: _____
 (B) PRIMARY SPRING: _____
 (C) SECONDARY SPRING: _____
 DROOP SPACER: _____ mm
 COMPRESSION SPACER: _____ mm
 (D) SPRING ADJUSTMENT: _____ mm

POWERSTROKE REAR SHOCKS

(A) PISTON: _____
 OIL WEIGHT: _____
 (B) PRIMARY SPRING: _____
 (C) SECONDARY SPRING: _____
 DROOP SPACER: _____ mm
 COMPRESSION SPACER: _____ mm
 (D) SPRING ADJUSTMENT: _____ mm

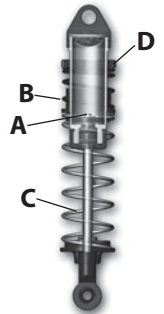

BATTERY PLACEMENT

BATTERY: _____
 PLACEMENT: _____

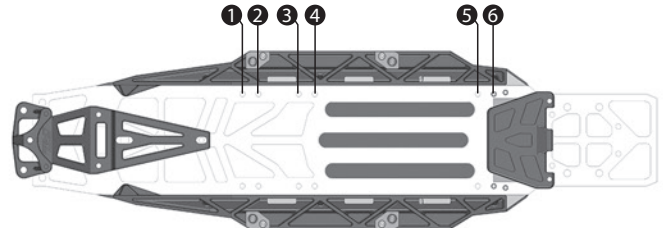

TRANSMISSION SETTINGS

PINION: _____
 SPUR GEAR: _____
 DIFF. OIL: _____

NOTES



PRO-LINE®

Pro-Line Racing
201 W. Lincoln St.
Banning, CA 92220

ProLineRacing.com

1-800-899-RACE (7223)

customerservice@prolinerracing.com



facebook.com/prolinerracing
[@prolinerracing](https://twitter.com/prolinerracing)